

**SÜT SAĞIM SİSTEMLERİ
ÇİFTLİK EKİPMANLARI**

**MILKING SYSTEM
FARM EQUIPMENT**

www.sutkar.com.tr





HAKKIMIZDA | ABOUT US

Firmamız 1978 yılında profesyonel et ve süt hayvancılığı ile ticari faaliyetlerine başlamış, 2006 yılında kurumsal bir yapı altında Sütkar'ı kurmuştur. Aynı yıl mobil sağım makineleri, süt sağım sistemleri ve yedek parçaların imalatına başlayan Sütkar, gerekli tüm kalite belgelerini almış, sürü yönetim sistemleri çalışmalarında başlamıştır. 2011 yılında sürü yönetim ve tanımlama sistemlerini üreticinin kullanımına sunan Sütkar, gelişen teknolojiyi sürekli kendi sistemine entegre etmiş ve halen bu amaç doğrultusunda çalışmalarına devam etmektedir.

Our facility has started its commercial activities with Professional meat and dairy farming in 1978 and it has lauched Sütkar as a corprate company in 2006. In the same year, Sütkar who started to manufacture mobile milking machines, milking systems and spare parts has received all the necessary quality certificated and has begun working on herd management systems. In 2011 Sütkar who presented herd management and definition systems to the customers integrate developing technology to own system and still continues to work with this purpose.



İÇİNDEKİLER

SÜT SAĞIM SİSTEMLERİ	5
KİLİT ARKASI	6
SAĞIM ODASI	8
HIZLI ÇIKIŞ	12
SÜRÜ YÖNETİMİ	16
TANIMLAMA, PEDOMETRE, TRANSPONDER	18
ELEKTRONİK SÜT ÖLÇER	19
KEÇİ VE KOYUN SAĞIM SİSTEMLERİ	21
SAĞIMHANE OTOMATİK YIKAMA SİSTEMİ	22
GÜBRE YÖNETİMİ SİSTEMLERİ	23
GÜBRE SIYIRICI	24
GÜBRE POMPASI	25
GÜBRE KARIŞTIRICI	25
GÜBRE SEPERATÖRÜ	26
HAYVAN KONFORU SİSTEMLERİ	27
HAYVAN FIRÇASI	28
YEMLİK KİLİT SETİ	29
BUZAĞI MAMA HAZIRLAMA MAKİNESİ	30
YATAK DURAK DEMİR SETİ	31
HAYVAN ALTI YATAĞI	31
DONMAZ SULUK	32
DEVİRMELİ SULUK	32
DÖKÜM SULUK	33
BUZAĞI KULÜBESİ	33
SOĞUTMA TANKLARI	35
YATATY SOĞUTMA TANKLARI	36
DİKEY SOĞUTMA TANKLARI	37
MOBİL SÜT SAĞIM MAKİNALARI	39
VAKUM MAKİNALARI	49
YEDEK PARÇALAR	55
SÜT ÖLÇER VE PEDOMETRE GRUBU	56
SÜT LASTİĞİ VE HORTUM GRUBU	58
PENÇE GRUBU	62
VAKUM TANKI GRUBU	65
REZERVE VE FANUS GRUBU	66
GÜĞÜM GRUBU	67
KAPAK GRUBU	67
PULSATÖR GRUBU	69
KAUÇUK GRUBU	70
CONTA GRUBU	71
PVC GRUBU	72
BAŞLIK GRUBU	74
TEKER GRUBU	75
FİBER VE GRAFIT PALET GRUBU	76
ANKASTRE GRUBU	77
KARMA GRUP	78
TEMİZLİK GRUBU	81

CONTENTS

MILKING SYSTEMS	5
PIPELINE	6
MILKING PARLOUR	8
FAST EXIT	12
HERD MANAGEMENT	16
DEFINING,PEDOMETER,TRANSPONDER	18
ELECTRONIC LACTOMETER	19
GOAT AND SHEEP MILKING SYSTEMS	21
MILKING PARLOUR AUTOMATIC WASHING SYSTEMS	22
MANURE MANAGEMENT SYSTEMS	23
MANURE STRIPPER	24
MANURE PUMP	25
MANURE MIXER	25
MANURE SEPERATOR	26
ANIMAL COMFORT SYSTEMS	27
ANIMAL BRUSH	28
CRIB LOCKING SET	29
CALF FEEDING TROLLEY SYSTEM	30
IRON REST STATION SET	31
ANIMAL BED	31
FROST-PROOF DRINKING BOW	32
TILT-OVER DRINKING BOWL	32
CASTING DRINKING BOWL	33
CALF COTTAGE	33
COOLING TANK	35
HORIZONTAL COOLING TANK	36
VERTICAL COOLING TANK	37
MOBILE MILKING MACHINE	39
VACUUM MACHINE	49
SPARE PARTS	55
PEDOMETER GROUP	56
MILK RUBBER AND HOSE GROUP	58
CLAW GORUP	62
VACUUM TANK GROUP	65
RESERVE AND BELL GLASS GROUP	66
BUCKET GROUP	67
LID GROUP	67
PULSATOR GROUP	69
RUBBER GROUP	70
ASKET GROUP	71
PVC GROUP	72
HEAD GROUP	74
TIRE GROUP	75
FIBER VE GRAPHITE PALLET GROUP	76
FIXED GROUP	77
MIXED GROUP	78
CLEANING GROUP	81

MİSYONUMUZ | OUR MISSION

“Sizin prestijiniz, bizim işimizdir” prensibiyle siz değerli dostlarımızın, müşterileriniz nezdindeki prestijiniz için çalışan ve yine siz değerli dostlarımıza hizmeti ilke edinen ve bu hizmeti en doğru, en güzel ve en profesyonel şekliyle sunmaya çalışan bir hizmetler topluluğuyuz.Sürekli yenilikçi ve yaratıcı düşünen, müşterilerinin geleceği için sorumluluk bilinciyle çalışan, kalite kavramını özümsemiş ve bunu yaptığı işlere yansıtabilen, değişimi hissedebilen, hizmetin en kalitelisini ve ürünün de en iyisini sunabilen bir kurum olmayı amaçlamaktayız.

Regarding the principle of “Your prestige is our business” We are a collection of services which is working for your prestige in the eyes of your customers and serving for the dear customers. We aim to become an innovative and creative company which is working in responsibility of the customers’ future and able to correlate the quality with the Works also which is aware of the change in order to serve and produce the best and most effective one.



SÜT SAĞIM SİSTEMLERİ MILKING SYSTEMS

Sağım odalarımızın süt kalitesini artırması amacıyla; süt hatlarında paslanmaz çelik borular; Süt ön toplayıcı ve süt transfer pompalarında çelik malzeme, sütün hijyenik ortamda saklanabilmesi amacıyla soğutma sistemine sahip süt bekleme tankları paslanmaz çelik malzemeden imal edilmiştir. Sağım odamızda sağım sonrası süt hatları ve sağım başlıklarını otomatik temizleme sistemi geliştirilmiştir.

In order to increase the milk quality of our milking rooms; It has been used stainless steel pipes in the milking line and the milk pre-collector and milk transfer pumps are made of stainless steel. Additionally for storing the milk in a hygienic room in order to store the milk in hygienic environment, milk waiting tanks with cooling system are made of stainless steel material. In milking parlour after milking milk lines and automatic milking heads cleaning system are developed.



KİLİT ARKASI | PIPELINE

İnşaat gerektirmeyen ya da yeterli yeri bulunmayan üretimhanelerde ağıl ya da açık alana kurulabilen merkezi sağım sistemidir. Üretici 7-8 dakika içerisinde 12 sağmalı aynı anda sağabilir, ve sağım sırasında ürettiği sütü otomatik olarak soğutma tankına aktarabilir.

Kilit arkası teknik özellikler

- Vakum pompaları; A sınıfı, yağlı paletli ve dahili vakum tankıdır.
- Montajı kilit arasına montajlanmaktadır.
- Kapasitesi 1x6 ile 1x12 arasında yapılabilmektedir.
- Kilit arkası sağım sistemleri yıkama (kapalı devre yıkama sistemi) sisteme dahildir.
- Aynı zamanda yıkama program ayarlamasını sağlayan temizlik madde alım zamanı durulama zamanı sağlayan PLC ekranlı otomatik yıkama paketini de opsiyonel olarak süt kalitesini ve hijyeni bozmadan üretim zincirini başlamasını sağlamaktayız.
- 2 yıl garantilidir.

It is a central milking system that can be installed in a corral or open area in the production facilities that do not require construction or where there is not enough place. Producer can milk at the same time with 12 springs in 7-8 minutes and can automatically transfer milk produced during milking to cooling tank.

Pipeline Technical Specifications

- Vacuum pumps: A Class, has oiled crawler and built-in vacuum tank.
- Installation is mounted between the lock.
- User can change capacity between 1x6 and 1x12
- Pipeline system washing (closed circuit washing system) is included in the system
- Cleaning at the same time providing washing program adjustment item receiving time rinsing time providing PLC display automatic washing package as well as optional milk quality and We ensure that the production chain starts without disturbing the hygiene.
- 2 years warranty

STOK KODU
STOCK CODEÜRÜN ADI
PRODUCT NAMEÜRÜN AÇIKLAMASI
PRODUCT DESCRIPTION

STOK KODU STOCK CODE	ÜRÜN ADI PRODUCT NAME	ÜRÜN AÇIKLAMASI PRODUCT DESCRIPTION
STK-0026	1x6 KİLİT ARKASI BOŞ PAKET 1x6 PIPELINE EMPTY PACKAGE	PULSASYON, MANUEL YIKAMA TİPİ KAPALI DEVRE PULSATION, MANUAL WASH TYPE CLOSED CIRCUIT
STK-0026-1	1x6 KİLİT ARKASI ORTA PAKET PIPELINE MEDIUM PACKAGE	ELEKTRONİK PULSASYON, OTOMATİK YIKAMA ELECTRONIC PULSTION, AUTOMATIC WASH
STK-0026-2	1x6 KİLİT ARKASI FULL PAKET 1x6 PIPELINE FULL PACKAGE	ELEKTRONİK PULSASYON, OTOMATİK YIKAMA SÜT ÖLÇÜM SEÇENEĞİ DİJİTAL YADA MANUEL ELECTRONIC PULSTION, AUTOMATIC WASH WITH LACTOMETER (DIGITAL OR MANUEL)
STK-0027	1x7 KİLİT ARKASI BOŞ PAKET 1x7 PIPELINE EMPTY PACKAGE	PULSASYON, MANUEL YIKAMA TİPİ KAPALI DEVRE PULSATION, MANUAL WASH TYPE CLOSED CIRCUIT
STK-0027-1	1x7 KİLİT ARKASI ORTA PAKET 1x7 PIPELINE MEDIUM PACKAGE	ELEKTRONİK PULSASYON, OTOMATİK YIKAMA ELECTRONIC PULSTION, AUTOMATIC WASH
STK-0027-2	1x7 KİLİT ARKASI FULL PAKET 1x7 PIPELINE FULL PACKAGE	ELEKTRONİK PULSASYON, OTOMATİK YIKAMA SÜT ÖLÇÜM SEÇENEĞİ DİJİTAL YADA MANUEL ELECTRONIC PULSTION, AUTOMATIC WASH WITH LACTOMETER (DIGITAL OR MANUEL)
STK-0028	1x8 KİLİT ARKASI BOŞ PAKET 1x8 PIPELINE EMPTY PACKAGE	PULSASYON, MANUEL YIKAMA TİPİ KAPALI DEVRE PULSATION, MANUAL WASH TYPE CLOSED CIRCUIT
STK-0028-1	1x8 KİLİT ARKASI ORTA PAKET 1x8 PIPELINE MEDIUM PACKAGE	ELEKTRONİK PULSASYON, OTOMATİK YIKAMA ELECTRONIC PULSTION, AUTOMATIC WASH
STK-0028-2	1x8 KİLİT ARKASI FULL PAKET 1x8 PIPELINE FULL PACKAGE	ELEKTRONİK PULSASYON, OTOMATİK YIKAMA SÜT ÖLÇÜM SEÇENEĞİ DİJİTAL YADA MANUEL ELECTRONIC PULSTION, AUTOMATIC WASH WITH LACTOMETER (DIGITAL OR MANUEL)
STK-0029	1x9 KİLİT ARKASI BOŞ PAKET 1x9 PIPELINE EMPTY PACKAGE	PULSASYON, MANUEL YIKAMA TİPİ KAPALI DEVRE PULSATION, MANUAL WASH TYPE CLOSED CIRCUIT
STK-0029-1	1x9 KİLİT ARKASI ORTA PAKET 1x9 PIPELINE MEDIUM PACKAGE	ELEKTRONİK PULSASYON, OTOMATİK YIKAMA ELECTRONIC PULSTION, AUTOMATIC WASH
STK-0029-2	1x9 KİLİT ARKASI FULL PAKET 1x9 PIPELINE FULL PACKAGE	ELEKTRONİK PULSASYON, OTOMATİK YIKAMA SÜT ÖLÇÜM SEÇENEĞİ DİJİTAL YADA MANUEL ELECTRONIC PULSTION, AUTOMATIC WASH WITH LACTOMETER (DIGITAL OR MANUEL)
STK-0030	1x10 KİLİT ARKASI BOŞ PAKET 1x10 PIPELINE EMPTY PACKAGE	PULSASYON, MANUEL YIKAMA TİPİ KAPALI DEVRE PULSATION, MANUAL WASH TYPE CLOSED CIRCUIT
STK-0030-1	1x10 KİLİT ARKASI ORTA PAKET 1x10 PIPELINE MEDIUM PACKAGE	ELEKTRONİK PULSASYON, OTOMATİK YIKAMA ELECTRONIC PULSTION, AUTOMATIC WASH
STK-0030-2	1x10 KİLİT ARKASI FULL PAKET 1x10 PIPELINE FULL PACKAGE	ELEKTRONİK PULSASYON, OTOMATİK YIKAMA SÜT ÖLÇÜM SEÇENEĞİ DİJİTAL YADA MANUEL ELECTRONIC PULSTION, AUTOMATIC WASH WITH LACTOMETER (DIGITAL OR MANUEL)
STK-0031	1x11 KİLİT ARKASI BOŞ PAKET 1x11 PIPELINE EMPTY PACKAGE	PULSASYON, MANUEL YIKAMA TİPİ KAPALI DEVRE PULSATION, MANUAL WASH TYPE CLOSED CIRCUIT
STK-0031-1	1x11 KİLİT ARKASI ORTA PAKET 1x11 PIPELINE MEDIUM PACKAGE	ELEKTRONİK PULSASYON, OTOMATİK YIKAMA ELECTRONIC PULSTION, AUTOMATIC WASH
STK-0031-2	1x11 KİLİT ARKASI FULL PAKET 1x11 PIPELINE FULL PACKAGE	ELEKTRONİK PULSASYON, OTOMATİK YIKAMA SÜT ÖLÇÜM SEÇENEĞİ DİJİTAL YADA MANUEL ELECTRONIC PULSTION, AUTOMATIC WASH WITH LACTOMETER (DIGITAL OR MANUEL)
STK-0032	1x12 KİLİT ARKASI BOŞ PAKET 1x12 PIPELINE EMPTY PACKAGE	PULSASYON, MANUEL YIKAMA TİPİ KAPALI DEVRE PULSATION, MANUAL WASH TYPE CLOSED CIRCUIT
STK-0032-1	1x12 KİLİT ARKASI ORTA PAKET 1x12 PIPELINE MEDIUM PACKAGE	ELEKTRONİK PULSASYON, OTOMATİK YIKAMA ELECTRONIC PULSTION, AUTOMATIC WASH
STK-0032-2	1x12 KİLİT ARKASI FULL PAKET 1x12 PIPELINE FULL PACKAGE	ELEKTRONİK PULSASYON, OTOMATİK YIKAMA SÜT ÖLÇÜM SEÇENEĞİ DİJİTAL YADA MANUEL ELECTRONIC PULSTION, AUTOMATIC WASH WITH LACTOMETER (DIGITAL OR MANUEL)
STK-0033	1x15 KİLİT ARKASI BOŞ PAKET 1x15 PIPELINE EMPTY PACKAGE	PULSASYON, MANUEL YIKAMA TİPİ KAPALI DEVRE PULSATION, MANUAL WASH TYPE CLOSED CIRCUIT
STK-0033-1	1x15 KİLİT ARKASI ORTA PAKET 1x15 PIPELINE MEDIUM PACKAGE	ELEKTRONİK PULSASYON, OTOMATİK YIKAMA ELECTRONIC PULSTION, AUTOMATIC WASH
STK-0033-2	1x15 KİLİT ARKASI FULL PAKET 1x15 PIPELINE FULL PACKAGE	ELEKTRONİK PULSASYON, OTOMATİK YIKAMA SÜT ÖLÇÜM SEÇENEĞİ DİJİTAL YADA MANUEL ELECTRONIC PULSTION, AUTOMATIC WASH WITH LACTOMETER (DIGITAL OR MANUEL)



SAĞIM ODASI | MILKING PARLOUR

Sütakar, süt sağımının, süt üreten işletmelerin hasat zamanı olduğunun bilincindedir. Bu bilinçle sağımın en verimli şekilde yapılabilmesi için; sağımhanelerinde sağmalların anatomisine uygun dizaynı, minimum iş gücü ve maksimum verimi, meme sağlığını korumak için uygun pulsasyonu (nabız değeri) sağlayan ekipmanları üretir ve kullanır. Balık kılçığı sağım sistemi, bugün kullanılan sistemler arasında iş gücü etkinliği en yüksek olanlardandır.

- Sağım durak demirleri; 48-3 mm sıcak daldırma galvaniz metal boru
- Montajı kaynaklı vidalı sistemdir.
- Kapasitesi 1x6 ile 2x15 arasında yapılabilmektedir.
- Süt pençe kapasitesi, yıkama sistemi, pulsatörler, süt ölçer ve otomatik başlık çıkarıcılar opsiyoneldir.
- Hayvan göğüs sağlık ve hijyeni için vakum basınç dağılımı tüm sağımdaki hayvanlara eşit olarak dağılması sağlanmaktadır.
- Bu sebep ile sağım sistemi hayvan göğüs ağrıları ya da yüksek vakum dağılımları sonucu göğüs defarmasyonu oluşumuna izin vermemektedir.
- Ayrıca sağım sisteminde kullanılan 30 derece açılı ile sağımının hayvan meme izlemesine olanak sağlamaktadır.
- Balık kılçığı sağım sistemi galvanizli malzemeden imal edilmekte olup hayvan dışkı asitlerinden oluşabilecek korozyonu en aza indirmeyi sağlamaktadır.
- Balık kılçığı durak demir seti işletmeniz içerisindeki genç hayvan yada orta yaşta hayvanınızın kılçık içerisindeki pozisyonunuzu planlamanıza yardımcı olmak için Sütakar kalitesi ile ayarlanabilir şekilde tasarlanmıştır.
- 2 yıl garantilidir.

Tek Taraflı Sağım Odası | One Sided Milking



Sütakar is aware of milking is the harvest time of milking companies. So to do milking in an effective way in parlours we produce and use equipment that brings us correct design , correct pulsation, minimum labor , maximum efficiency. Fishbone Milking System is the best system for maximum labor today.

- Milking Stop Irons 48-3 mm hot dipping galvanized metal pipe.
- Mounting is the screwing system without welding its
- Capacity between 1x6 and 2x15 .
- Milk claw capacity, washing system pulsations lactometer automatic header remover are optional.
- Vacuum pressure distribution for animal chest health and hygiene is evenly distributed to the animals in the whole milking.
- For this reason, the milking system does not allow the formation of chest deflation due to animal chest pains or high vacuum distribution.
- Also thanks to 30 degree in milking system milker can watch the animal.
- The fishbone milking system is manufactured from the glazed material and this minimizes the corrosion of animal stool acids .
- 2 years warranty.

Çift Taraflı Sağım Odası | Two Sided Milking



STOK KODU STOCK CODE	ÜRÜN ADI PRODUCT NAME	ÜRÜN AÇIKLAMASI PRODUCT DESCRIPTION
STK-0033-3	1X6 TEK TARAFLI SAĞIM ODASI BOŞ PAKET 1X6 ONE SIDED MILKING PARLOUR EMPTY PACKAGE	PULSASYON , MANUEL YIKAMA TİPİ KAPALI DEVRE PULSATION, MANUAL WASH TYPE CLOSED CIRCUIT
STK-0033-4	1X6 TEK TARAFLI SAĞIM ODASI ORTA PAKET 1X6 ONE SIDED MILKING PARLOUR MEDIUM PACKAGE	ELEKTRONİK PULSASYON , OTOMATİK YIKAMA ELECTRONIC PULASTION, AUTOMATIC WASH
STK-0033-5	1X6 TEK TARAFLI SAĞIM ODASI FULL PAKET 1X6 ONE SIDED MILKING PARLOUR FULL PACKAGE	ELEKTRONİK PULSASYON , OTOMATİK YIKAMA SÜT ÖLÇÜM SEÇENEĞİ DİJİTAL YADA MANUEL, SÜRÜ YÖNETİM ENTEGRASYONU ELECTRONIC PULASTION, AUTOMATIC WASH WITH LACTOMETER (DIGITAL OR MANUEL)
STK-0034	1X8 TEK TARAFLI SAĞIM ODASI BOŞ PAKET 1X8 ONE SIDED MILKING PARLOUR EMPTY PACKAGE	PULSASYON , MANUEL YIKAMA TİPİ KAPALI DEVRE PULSATION, MANUAL WASH TYPE CLOSED CIRCUIT
STK-0034-1	1X8 TEK TARAFLI SAĞIM ODASI ORTA PAKET 1X8 ONE SIDED MILKING PARLOUR MEDIUM PACKAGE	ELEKTRONİK PULSASYON , OTOMATİK YIKAMA ELECTRONIC PULASTION, AUTOMATIC WASH
STK-0034-2	1X8 TEK TARAFLI SAĞIM ODASI FULL PAKET 1X8 ONE SIDED MILKING PARLOUR FULL PACKAGE	ELEKTRONİK PULSASYON , OTOMATİK YIKAMA SÜT ÖLÇÜM SEÇENEĞİ DİJİTAL YADA MANUEL, SÜRÜ YÖNETİM ENTEGRASYONU ELECTRONIC PULASTION, AUTOMATIC WASH WITH LACTOMETER (DIGITAL OR MANUEL)
STK-0035	1X9 TEK TARAFLI SAĞIM ODASI BOŞ PAKET 1X9 ONE SIDED MILKING PARLOUR EMPTY PACKAGE	PULSASYON , MANUEL YIKAMA TİPİ KAPALI DEVRE PULSATION, MANUAL WASH TYPE CLOSED CIRCUIT
STK-0035-1	1X9 TEK TARAFLI SAĞIM ODASI ORTA PAKET 1X9 ONE SIDED MILKING PARLOUR MEDIUM PACKAGE	ELEKTRONİK PULSASYON , OTOMATİK YIKAMA ELECTRONIC PULASTION, AUTOMATIC WASH
STK-0035-2	1X9 TEK TARAFLI SAĞIM ODASI FULL PAKET 1X9 ONE SIDED MILKING PARLOUR FULL PACKAGE	ELEKTRONİK PULSASYON , OTOMATİK YIKAMA SÜT ÖLÇÜM SEÇENEĞİ DİJİTAL YADA MANUEL, SÜRÜ YÖNETİM ENTEGRASYONU ELECTRONIC PULASTION, AUTOMATIC WASH WITH LACTOMETER (DIGITAL OR MANUEL)
STK-0036	1X10 TEK TARAFLI SAĞIM ODASI BOŞ PAKET 1X10 ONE SIDED MILKING PARLOUR EMPTY PACKAGE	PULSASYON , MANUEL YIKAMA TİPİ KAPALI DEVRE PULSATION, MANUAL WASH TYPE CLOSED CIRCUIT
STK-0036-1	1X10 TEK TARAFLI SAĞIM ODASI ORTA PAKET 1X10 ONE SIDED MILKING PARLOUR MEDIUM PACKAGE	ELEKTRONİK PULSASYON , OTOMATİK YIKAMA ELECTRONIC PULASTION, AUTOMATIC WASH
STK-0036-2	1X10 TEK TARAFLI SAĞIM ODASI FULL PAKET 1X10 ONE SIDED MILKING PARLOUR FULL PACKAGE	ELEKTRONİK PULSASYON , OTOMATİK YIKAMA SÜT ÖLÇÜM SEÇENEĞİ DİJİTAL YADA MANUEL, SÜRÜ YÖNETİM ENTEGRASYONU ELECTRONIC PULASTION, AUTOMATIC WASH WITH LACTOMETER (DIGITAL OR MANUEL)
STK-0036-3	1X11 TEK TARAFLI SAĞIM ODASI BOŞ PAKET 1X11 ONE SIDED MILKING PARLOUR EMPTY PACKAGE	PULSASYON , MANUEL YIKAMA TİPİ KAPALI DEVRE PULSATION, MANUAL WASH TYPE CLOSED CIRCUIT
STK-0036-4	1X11 TEK TARAFLI SAĞIM ODASI ORTA PAKET 1X11 ONE SIDED MILKING PARLOUR MEDIUM PACKAGE	ELEKTRONİK PULSASYON , OTOMATİK YIKAMA ELECTRONIC PULASTION, AUTOMATIC WASH
STK-0036-5	1X11 TEK TARAFLI SAĞIM ODASI FULL PAKET 1X11 ONE SIDED MILKING PARLOUR FULL PACKAGE	ELEKTRONİK PULSASYON , OTOMATİK YIKAMA SÜT ÖLÇÜM SEÇENEĞİ DİJİTAL YADA MANUEL, SÜRÜ YÖNETİM ENTEGRASYONU ELECTRONIC PULASTION, AUTOMATIC WASH WITH LACTOMETER (DIGITAL OR MANUEL)
STK-0037	1X12 TEK TARAFLI SAĞIM ODASI BOŞ PAKET 1X12 ONE SIDED MILKING PARLOUR EMPTY PACKAGE	PULSASYON , MANUEL YIKAMA TİPİ KAPALI DEVRE PULSATION, MANUAL WASH TYPE CLOSED CIRCUIT
STK-0037-1	1X12 TEK TARAFLI SAĞIM ODASI ORTA PAKET 1X12 ONE SIDED MILKING PARLOUR MEDIUM PACKAGE	ELEKTRONİK PULSASYON , OTOMATİK YIKAMA ELECTRONIC PULASTION, AUTOMATIC WASH
STK-0037-2	1X12 TEK TARAFLI SAĞIM ODASI FULL PAKET 1X12 ONE SIDED MILKING PARLOUR FULL PACKAGE	ELEKTRONİK PULSASYON , OTOMATİK YIKAMA SÜT ÖLÇÜM SEÇENEĞİ DİJİTAL YADA MANUEL, SÜRÜ YÖNETİM ENTEGRASYONU ELECTRONIC PULASTION, AUTOMATIC WASH WITH LACTOMETER (DIGITAL OR MANUEL)
STK-0037-3	1X15 TEK TARAFLI SAĞIM ODASI BOŞ PAKET 1X15 ONE SIDED MILKING PARLOUR EMPTY PACKAGE	PULSASYON , MANUEL YIKAMA TİPİ KAPALI DEVRE PULSATION, MANUAL WASH TYPE CLOSED CIRCUIT
STK-0037-4	1X15 TEK TARAFLI SAĞIM ODASI ORTA PAKET 1X15 ONE SIDED MILKING PARLOUR MEDIUM PACKAGE	ELEKTRONİK PULSASYON , OTOMATİK YIKAMA ELECTRONIC PULASTION, AUTOMATIC WASH
STK-0037-5	1X15 TEK TARAFLI SAĞIM ODASI FULL PAKET 1X15 ONE SIDED MILKING PARLOUR FULL PACKAGE	ELEKTRONİK PULSASYON , OTOMATİK YIKAMA SÜT ÖLÇÜM SEÇENEĞİ DİJİTAL YADA MANUEL, SÜRÜ YÖNETİM ENTEGRASYONU ELECTRONIC PULASTION, AUTOMATIC WASH WITH LACTOMETER (DIGITAL OR MANUEL)

NOT | NOTE

BU PAKETLERİMİZDE Ø48 ÇAPINDA 3MM ET KALINLIĞINDA GALVANİZLİ DURAK DEMİR SETİ, GALVANİZLİ MERDİVEN, ETEK ALTI PİSLİK SAÇLARINA, AÇI KAPISI HAYVAN SIKIŞTIRMA KAPISI DAHİLDİR.

THESE PACKAGES INCLUDE Ø48-WIDE 3MM THICK GALVANIZED STOP IRON SET, GALVANIZED LADDER, SKIRT UNDER THE DIRT HAIR, ANGLE DOOR, ANIMAL COMPRESSION DOOR.



STOK KODU STOCK CODE	ÜRÜN ADI PRODUCT NAME	ÜRÜN AÇIKLAMASI PRODUCT DESCRIPTION
STK-0038	2X4 TEK TARAFLI SAĞIM ODASI BOŞ PAKET 2x4 ONE SIDED MILKING PARLOUR EMPTY PACKAGE	PULSASYON , MANUEL YIKAMA TİPİ KAPALI DEVRE PULSATION, MANUAL WASH TYPE CLOSED CIRCUIT
STK-0038-1	2X4 TEK TARAFLI SAĞIM ODASI ORTA PAKET 2x4 ONE SIDED MILKING PARLOUR MEDIUM PACKAGE	ELEKTRONİK PULSASYON , OTOMATİK YIKAMA ELECTRONIC PULASTION, AUTOMATIC WASH
STK-0038-2	2x4 TEK TARAFLI SAĞIM ODASI FULL PAKET 2x4 ONE SIDED MILKING PARLOUR FULL PACKAGE	ELEKTRONİK PULSASYON , OTOMATİK YIKAMA SÜT ÖLÇÜM SEÇENEĞİ DİJİTAL YADA MANUEL, SÜRÜ YÖNETİM ENTEGRASYONU ELECTRONIC PULASTION, AUTOMATIC WASH WITH LACTOMETER (DIGITAL OR MANUEL)
STK-0039	2X5 TEK TARAFLI SAĞIM ODASI BOŞ PAKET 2x5 ONE SIDED MILKING PARLOUR EMPTY PACKAGE	PULSASYON , MANUEL YIKAMA TİPİ KAPALI DEVRE PULSATION, MANUAL WASH TYPE CLOSED CIRCUIT
STK-0039-1	2X5 TEK TARAFLI SAĞIM ODASI ORTA PAKET 2x5 ONE SIDED MILKING PARLOUR MEDIUM PACKAGE	ELEKTRONİK PULSASYON , OTOMATİK YIKAMA ELECTRONIC PULASTION, AUTOMATIC WASH
STK-0039-2	2x5 TEK TARAFLI SAĞIM ODASI FULL PAKET 2x5 ONE SIDED MILKING PARLOUR FULL PACKAGE	ELEKTRONİK PULSASYON , OTOMATİK YIKAMA SÜT ÖLÇÜM SEÇENEĞİ DİJİTAL YADA MANUEL, SÜRÜ YÖNETİM ENTEGRASYONU ELECTRONIC PULASTION, AUTOMATIC WASH WITH LACTOMETER (DIGITAL OR MANUEL)
STK-0040	2X6 TEK TARAFLI SAĞIM ODASI BOŞ PAKET 2x6 ONE SIDED MILKING PARLOUR EMPTY PACKAGE	PULSASYON , MANUEL YIKAMA TİPİ KAPALI DEVRE PULSATION, MANUAL WASH TYPE CLOSED CIRCUIT
STK-0040-1	2X6 TEK TARAFLI SAĞIM ODASI ORTA PAKET 2x6 ONE SIDED MILKING PARLOUR MEDIUM PACKAGE	ELEKTRONİK PULSASYON , OTOMATİK YIKAMA ELECTRONIC PULASTION, AUTOMATIC WASH
STK-0040-2	2x6 TEK TARAFLI SAĞIM ODASI FULL PAKET 2x6 ONE SIDED MILKING PARLOUR FULL PACKAGE	ELEKTRONİK PULSASYON , OTOMATİK YIKAMA SÜT ÖLÇÜM SEÇENEĞİ DİJİTAL YADA MANUEL, SÜRÜ YÖNETİM ENTEGRASYONU ELECTRONIC PULASTION, AUTOMATIC WASH WITH LACTOMETER (DIGITAL OR MANUEL)
STK-0041	2X7 TEK TARAFLI SAĞIM ODASI BOŞ PAKET 2x7 ONE SIDED MILKING PARLOUR EMPTY PACKAGE	PULSASYON , MANUEL YIKAMA TİPİ KAPALI DEVRE PULSATION, MANUAL WASH TYPE CLOSED CIRCUIT
STK-0041-1	2X7 TEK TARAFLI SAĞIM ODASI ORTA PAKET 2x7 ONE SIDED MILKING PARLOUR MEDIUM PACKAGE	ELEKTRONİK PULSASYON , OTOMATİK YIKAMA ELECTRONIC PULASTION, AUTOMATIC WASH
STK-0041-2	2x7 TEK TARAFLI SAĞIM ODASI FULL PAKET 2x7 ONE SIDED MILKING PARLOUR FULL PACKAGE	ELEKTRONİK PULSASYON , OTOMATİK YIKAMA SÜT ÖLÇÜM SEÇENEĞİ DİJİTAL YADA MANUEL, SÜRÜ YÖNETİM ENTEGRASYONU ELECTRONIC PULASTION, AUTOMATIC WASH WITH LACTOMETER (DIGITAL OR MANUEL)
STK-0042	2X8 TEK TARAFLI SAĞIM ODASI BOŞ PAKET 2x8 ONE SIDED MILKING PARLOUR EMPTY PACKAGE	PULSASYON , MANUEL YIKAMA TİPİ KAPALI DEVRE PULSATION, MANUAL WASH TYPE CLOSED CIRCUIT
STK-0042-1	2X8 TEK TARAFLI SAĞIM ODASI ORTA PAKET 2x8 ONE SIDED MILKING PARLOUR MEDIUM PACKAGE	ELEKTRONİK PULSASYON , OTOMATİK YIKAMA ELECTRONIC PULASTION, AUTOMATIC WASH
STK-0042-2	2x8 TEK TARAFLI SAĞIM ODASI FULL PAKET 2x8 ONE SIDED MILKING PARLOUR FULL PACKAGE	ELEKTRONİK PULSASYON , OTOMATİK YIKAMA SÜT ÖLÇÜM SEÇENEĞİ DİJİTAL YADA MANUEL, SÜRÜ YÖNETİM ENTEGRASYONU ELECTRONIC PULASTION, AUTOMATIC WASH WITH LACTOMETER (DIGITAL OR MANUEL)
STK-0043	2X10 TEK TARAFLI SAĞIM ODASI BOŞ PAKET 2x10 ONE SIDED MILKING PARLOUR EMPTY PACKAGE	PULSASYON , MANUEL YIKAMA TİPİ KAPALI DEVRE PULSATION, MANUAL WASH TYPE CLOSED CIRCUIT
STK-0043-1	2X10 TEK TARAFLI SAĞIM ODASI ORTA PAKET 2x10 ONE SIDED MILKING PARLOUR MEDIUM PACKAGE	ELEKTRONİK PULSASYON , OTOMATİK YIKAMA ELECTRONIC PULASTION, AUTOMATIC WASH
STK-0043-2	2x10 TEK TARAFLI SAĞIM ODASI FULL PAKET 2x10 ONE SIDED MILKING PARLOUR FULL PACKAGE	ELEKTRONİK PULSASYON , OTOMATİK YIKAMA SÜT ÖLÇÜM SEÇENEĞİ DİJİTAL YADA MANUEL, SÜRÜ YÖNETİM ENTEGRASYONU ELECTRONIC PULASTION, AUTOMATIC WASH WITH LACTOMETER (DIGITAL OR MANUEL)
STK-0044	2X12 TEK TARAFLI SAĞIM ODASI BOŞ PAKET 2x12 ONE SIDED MILKING PARLOUR EMPTY PACKAGE	PULSASYON , MANUEL YIKAMA TİPİ KAPALI DEVRE PULSATION, MANUAL WASH TYPE CLOSED CIRCUIT
STK-0044-1	2X12 TEK TARAFLI SAĞIM ODASI ORTA PAKET 2x12 ONE SIDED MILKING PARLOUR MEDIUM PACKAGE	ELEKTRONİK PULSASYON , OTOMATİK YIKAMA ELECTRONIC PULASTION, AUTOMATIC WASH
STK-0044-2	2x12 TEK TARAFLI SAĞIM ODASI FULL PAKET 2x12 ONE SIDED MILKING PARLOUR FULL PACKAGE	ELEKTRONİK PULSASYON , OTOMATİK YIKAMA SÜT ÖLÇÜM SEÇENEĞİ DİJİTAL YADA MANUEL, ELECTRONIC PULASTION, AUTOMATIC WASH WITH LACTOMETER (DIGITAL OR MANUEL)
STK-0045	2X15 TEK TARAFLI SAĞIM ODASI BOŞ PAKET 2x15 ONE SIDED MILKING PARLOUR EMPTY PACKAGE	PULSASYON , MANUEL YIKAMA TİPİ KAPALI DEVRE PULSATION, MANUAL WASH TYPE CLOSED CIRCUIT
STK-0045-1	2X15 TEK TARAFLI SAĞIM ODASI ORTA PAKET 2x15 ONE SIDED MILKING PARLOUR MEDIUM PACKAGE	ELEKTRONİK PULSASYON , OTOMATİK YIKAMA ELECTRONIC PULASTION, AUTOMATIC WASH
STK-0045-2	2x15 TEK TARAFLI SAĞIM ODASI FULL PAKET 2x15 ONE SIDED MILKING PARLOUR FULL PACKAGE	ELEKTRONİK PULSASYON , OTOMATİK YIKAMA SÜT ÖLÇÜM SEÇENEĞİ DİJİTAL YADA MANUEL, SÜRÜ YÖNETİM ENTEGRASYONU ELECTRONIC PULASTION, AUTOMATIC WASH WITH LACTOMETER (DIGITAL OR MANUEL)



NOT | NOTE

BU PAKETLERİMİZDE Ø 48 ÇAPINDA 3MM ET KALINLIĞINDA DURAK DEMİR SETİ, 2 ADET GALVANİZLİ MERDİVEN, ETEK ALTI PİSLİK SAÇLARINA, 2 ADET AÇI KAPISI HAYVAN SIKIŞTIRMA KAPISI DAHİLDİR.

IN THESE PACKAGES 2 ANIMAL COMPRESSION DOOR AND 2 ANGLE DOOR INCLUDE TO Ø 48 DIAMETER 3MM THICK IRON STATION SET, 2 GALVANIZED LADDER, UNDERSKIRT DROPPING HAIR.





HIZLI ÇIKIŞ | FAST EXIT

- Profesyonel işletmeler için tasarlanmış süt sağım ve hayvan bekleme süresi daha da kısaltılmıştır.
- Hızlı çıkış sağım yapılacak hayvanların hızlı ve doğru komum almasını sağlamanı sağlayarak işletmelere fayda sağlamak için Sütakar kalitesi ile tasarlanmıştır.
- Sağımhane sağım hayvanlarının yürüyüş yolları ile hızlı bir şekilde sağım konumlarını alması, sağım işlemindeki hayvanların stres oluşumunu engellemek için hayvanların ön tarafı açık olmaktadır.
- Sağım bitiminden sonra ön paralel olarak çıkış yapmasına olanak tanımaktadır. Sağım hayvanlarının paralel yerleşmesi ve hayvanların sağımdan boşaltılması pnömomatik olarak sağımhanede çalışacak elaman sayısının düşürülme imkanı tanımak ile beraber sağımhanede sağlıklı hijyenik olarak sütün soğutma kanallarına yönlendirilmesine imkan sağlar.
- 1x10 ile 2x30 arası kurulmu sağlanmaktadır.
- Hızlı çıkış sağım sistemi tek taraflı ve çift taraflı olmak üzere Sütakar kalitesi işletmelerin hizmetlerine sunulmuştur.

- It is designed for professional companies and milking and animal waiting time are reduced.
- It is designed with Sütakar quality to help companies with providing of getting fast and accurate position.
- Installation between 1x10 and 2x30 is provided
- Fast Exit milking system is presented to the enterprises of the company with one sided system and two sided system.



STOK KODU
STOCK CODE

ÜRÜN ADI
PRODUCT NAME

ÜRÜN AÇIKLAMASI
PRODUCT DESCRIPTION

STK-0046	1X10 TEK TARAFLI HIZLI ÇIKIŞ SAĞIM SİSTEMİ BOŞ PAKET 1X10 ONE SIDED FAST EXIT EMPTY PACKAGE	PULSASYON, MANUEL YIKAMA TİPİ KAPALI DEVRE PULSATION, MANUAL WASH TYPE CLOSED CIRCUIT
STK-0046-1	1X10 TEK TARAFLI HIZLI ÇIKIŞ SAĞIM SİSTEMİ ORTA PAKET 1X10 ONE SIDED FAST EXIT MEDIUM PACKAGE	ELEKTRONİK PULSASYON, OTOMATİK YIKAMA ELECTRONIC PULASTION, AUTOMATIC WASH
STK-0046-2	1x10 TEK TARAFLI HIZLI ÇIKIŞ SAĞIM SİSTEMİ FULL PAKET 1x10 ONE SIDED FAST EXIT FULL PACKAGE	ELEKTRONİK PULSASYON , OTOMATİK YIKAMA SÜT ÖLÇÜM SEÇENEĞİ DİJİTAL YADA MANUEL, SÜRÜ YÖNETİM ENTEGRASYONU ELECTRONIC PULASTION, AUTOMATIC WASH WITH LACTOMETER (DIGITAL OR MANUEL)
STK-0047	1X12 TEK TARAFLI HIZLI ÇIKIŞ SAĞIM SİSTEMİ BOŞ PAKET 1X12 ONE SIDED FAST EXIT EMPTY PACKAGE	PULSASYON, MANUEL YIKAMA TİPİ KAPALI DEVRE PULSATION, MANUAL WASH TYPE CLOSED CIRCUIT
STK-0047-1	1X12 TEK TARAFLI HIZLI ÇIKIŞ SAĞIM SİSTEMİ ORTA PAKET 1X12 ONE SIDED FAST EXIT EMPTY PACKAGE	ELEKTRONİK PULSASYON, OTOMATİK YIKAMA PULSATION, MANUAL WASH TYPE CLOSED CIRCUIT
STK-0047-2	1x12 TEK TARAFLI HIZLI ÇIKIŞ SAĞIM SİSTEMİ FULL PAKET 1x12 ONE SIDED FAST EXIT MEDIUM PACKAGE	ELEKTRONİK PULSASYON , OTOMATİK YIKAMA SÜT ÖLÇÜM SEÇENEĞİ DİJİTAL YADA MANUEL, SÜRÜ YÖNETİM ENTEGRASYONU ELECTRONIC PULASTION, AUTOMATIC WASH
STK-0048	1X14 TEK TARAFLI HIZLI ÇIKIŞ SAĞIM SİSTEMİ BOŞ PAKET 1X14 ONE SIDED FAST EXIT FULL PACKAGE	PULSASYON, MANUEL YIKAMA TİPİ KAPALI DEVRE ELECTRONIC PULASTION, AUTOMATIC WASH WITH LACTOMETER (DIGITAL OR MANUEL)
STK-0048-1	1X14 TEK TARAFLI HIZLI ÇIKIŞ SAĞIM SİSTEMİ ORTA PAKET 1X14 ONE SIDED FAST EXIT EMPTY PACKAGE	ELEKTRONİK PULSASYON, OTOMATİK YIKAMA PULSATION, MANUAL WASH TYPE CLOSED CIRCUIT
STK-0048-2	1x14 TEK TARAFLI HIZLI ÇIKIŞ SAĞIM SİSTEMİ FULL PAKET 1x14 ONE SIDED FAST EXIT MEDIUM PACKAGE	ELEKTRONİK PULSASYON , OTOMATİK YIKAMA SÜT ÖLÇÜM SEÇENEĞİ DİJİTAL YADA MANUEL, SÜRÜ YÖNETİM ENTEGRASYONU ELECTRONIC PULASTION, AUTOMATIC WASH
STK-0049	1X16 TEK TARAFLI HIZLI ÇIKIŞ SAĞIM SİSTEMİ BOŞ PAKET 1X16 ONE SIDED FAST EXIT FULL PACKAGE	PULSASYON, MANUEL YIKAMA TİPİ KAPALI DEVRE ELECTRONIC PULASTION, AUTOMATIC WASH WITH LACTOMETER (DIGITAL OR MANUEL)
STK-0049-1	1X16 TEK TARAFLI HIZLI ÇIKIŞ SAĞIM SİSTEMİ ORTA PAKET 1X16 ONE SIDED FAST EXIT EMPTY PACKAGE	ELEKTRONİK PULSASYON, OTOMATİK YIKAMA PULSATION, MANUAL WASH TYPE CLOSED CIRCUIT
STK-0049-2	1x16 TEK TARAFLI HIZLI ÇIKIŞ SAĞIM SİSTEMİ FULL PAKET 1x16 ONE SIDED FAST EXIT MEDIUM PACKAGE	ELEKTRONİK PULSASYON , OTOMATİK YIKAMA SÜT ÖLÇÜM SEÇENEĞİ DİJİTAL YADA MANUEL, SÜRÜ YÖNETİM ENTEGRASYONU ELECTRONIC PULASTION, AUTOMATIC WASH
STK-0050	1X18 TEK TARAFLI HIZLI ÇIKIŞ SAĞIM SİSTEMİ BOŞ PAKET 1X18 ONE SIDED FAST EXIT FULL PACKAGE	PULSASYON, MANUEL YIKAMA TİPİ KAPALI DEVRE ELECTRONIC PULASTION, AUTOMATIC WASH WITH LACTOMETER (DIGITAL OR MANUEL)
STK-0050-1	1X18 TEK TARAFLI HIZLI ÇIKIŞ SAĞIM SİSTEMİ ORTA PAKET 1X18 ONE SIDED FAST EXIT EMPTY PACKAGE	ELEKTRONİK PULSASYON, OTOMATİK YIKAMA PULSATION, MANUAL WASH TYPE CLOSED CIRCUIT
STK-0050-2	1x18 TEK TARAFLI HIZLI ÇIKIŞ SAĞIM SİSTEMİ FULL PAKET 1x18 ONE SIDED FAST EXIT MEDIUM PACKAGE	ELEKTRONİK PULSASYON , OTOMATİK YIKAMA SÜT ÖLÇÜM SEÇENEĞİ DİJİTAL YADA MANUEL, SÜRÜ YÖNETİM ENTEGRASYONU ELECTRONIC PULASTION, AUTOMATIC WASH
STK-0051	1X20 TEK TARAFLI HIZLI ÇIKIŞ SAĞIM SİSTEMİ BOŞ PAKET 1X20 ONE SIDED FAST EXIT FULL PACKAGE	PULSASYON, MANUEL YIKAMA TİPİ KAPALI DEVRE ELECTRONIC PULASTION, AUTOMATIC WASH WITH LACTOMETER (DIGITAL OR MANUEL)
STK-0051-1	1X20 TEK TARAFLI HIZLI ÇIKIŞ SAĞIM SİSTEMİ ORTA PAKET 1X20 ONE SIDED FAST EXIT EMPTY PACKAGE	ELEKTRONİK PULSASYON, OTOMATİK YIKAMA PULSATION, MANUAL WASH TYPE CLOSED CIRCUIT
STK-0051-2	1x20 TEK TARAFLI HIZLI ÇIKIŞ SAĞIM SİSTEMİ FULL PAKET 1x20 ONE SIDED FAST EXIT MEDIUM PACKAGE	ELEKTRONİK PULSASYON , OTOMATİK YIKAMA SÜT ÖLÇÜM SEÇENEĞİ DİJİTAL YADA MANUEL, SÜRÜ YÖNETİM ENTEGRASYONU ELECTRONIC PULASTION, AUTOMATIC WASH



STOK KODU STOCK CODE	ÜRÜN ADI PRODUCT NAME	ÜRÜN AÇIKLAMASI PRODUCT DESCRIPTION
STK-0052	2X10 TEK TARAFLI HIZLI ÇIKIŞ SAĞIM SİSTEMİ BOŞ PAKET 2X10 ONE SIDED FAST EXIT FULL PACKAGE	PULSASYON , MANUEL YIKAMA TİPİ KAPALI DEVRE ELECTRONIC PULASTION, AUTOMATIC WASH WITH LACTOMETER (DIGITAL OR MANUEL)
STK-0052-1	2X10 TEK TARAFLI HIZLI ÇIKIŞ SAĞIM SİSTEMİ ORTA PAKET 2X10 ONE SIDED FAST EXIT EMPTY PACKAGE	ELEKTRONİK PULSASYON, OTOMATİK YIKAMA PULSATION, MANUAL WASH TYPE CLOSED CIRCUIT
STK-0052-2	2x10 TEK TARAFLI HIZLI ÇIKIŞ SAĞIM SİSTEMİ FULL PAKET 2x10 ONE SIDED FAST EXIT MEDIUM PACKAGE	ELEKTRONİK PULSASYON , OTOMATİK YIKAMA SÜT ÖLÇÜM SEÇENEĞİ DİJİTAL YADA MANUEL, SÜRÜ YÖNETİM ENTEGRASYONU PULSATION, MANUAL WASH TYPE CLOSED CIRCUIT
STK-0053	2X12 TEK TARAFLI HIZLI ÇIKIŞ SAĞIM SİSTEMİ BOŞ PAKET 2X12 ONE SIDED FAST EXIT EMPTY PACKAGE	PULSASYON , MANUEL YIKAMA TİPİ KAPALI DEVRE PULSATION, MANUAL WASH TYPE CLOSED CIRCUIT
STK-0053-1	2X12 TEK TARAFLI HIZLI ÇIKIŞ SAĞIM SİSTEMİ ORTA PAKET 2X12 ONE SIDED FAST EXIT MEDIUM PACKAGE	ELEKTRONİK PULSASYON, OTOMATİK YIKAMA ELECTRONIC PULASTION, AUTOMATIC WASH
STK-0053-2	2x12 TEK TARAFLI HIZLI ÇIKIŞ SAĞIM SİSTEMİ FULL PAKET 2x12 ONE SIDED FAST EXIT FULL PACKAGE	ELEKTRONİK PULSASYON , OTOMATİK YIKAMA SÜT ÖLÇÜM SEÇENEĞİ DİJİTAL YADA MANUEL, SÜRÜ YÖNETİM ENTEGRASYONU ELECTRONIC PULASTION, AUTOMATIC WASH WITH LACTOMETER (DIGITAL OR MANUEL)
STK-0054	2X14 TEK TARAFLI HIZLI ÇIKIŞ SAĞIM SİSTEMİ BOŞ PAKET 2X14 ONE SIDED FAST EXIT EMPTY PACKAGE	PULSASYON , MANUEL YIKAMA TİPİ KAPALI DEVRE PULSATION, MANUAL WASH TYPE CLOSED CIRCUIT
STK-0054-1	2X14 TEK TARAFLI HIZLI ÇIKIŞ SAĞIM SİSTEMİ ORTA PAKET 2X14 ONE SIDED FAST EXIT EMPTY PACKAGE	ELEKTRONİK PULSASYON, OTOMATİK YIKAMA PULSATION, MANUAL WASH TYPE CLOSED CIRCUIT
STK-0054-2	2x14 TEK TARAFLI HIZLI ÇIKIŞ SAĞIM SİSTEMİ FULL PAKET 2x14 ONE SIDED FAST EXIT MEDIUM PACKAGE	ELEKTRONİK PULSASYON , OTOMATİK YIKAMA SÜT ÖLÇÜM SEÇENEĞİ DİJİTAL YADA MANUEL, SÜRÜ YÖNETİM ENTEGRASYONU PULSATION, MANUAL WASH TYPE CLOSED CIRCUIT
STK-0055	2X16 TEK TARAFLI HIZLI ÇIKIŞ SAĞIM SİSTEMİ BOŞ PAKET 2X16 ONE SIDED FAST EXIT FULL PACKAGE	PULSASYON , MANUEL YIKAMA TİPİ KAPALI DEVRE ELECTRONIC PULASTION, AUTOMATIC WASH WITH LACTOMETER (DIGITAL OR MANUEL)
STK-0055-1	2X16 TEK TARAFLI HIZLI ÇIKIŞ SAĞIM SİSTEMİ ORTA PAKET 2X16 ONE SIDED FAST EXIT EMPTY PACKAGE	ELEKTRONİK PULSASYON, OTOMATİK YIKAMA PULSATION, MANUAL WASH TYPE CLOSED CIRCUIT
STK-0055-2	2x16 TEK TARAFLI HIZLI ÇIKIŞ SAĞIM SİSTEMİ FULL PAKET 2x16 ONE SIDED FAST EXIT MEDIUM PACKAGE	ELEKTRONİK PULSASYON , OTOMATİK YIKAMA SÜT ÖLÇÜM SEÇENEĞİ DİJİTAL YADA MANUEL, SÜRÜ YÖNETİM ENTEGRASYONU ELECTRONIC PULASTION, AUTOMATIC WASH
STK-0056	2X18 TEK TARAFLI HIZLI ÇIKIŞ SAĞIM SİSTEMİ BOŞ PAKET 2X18 ONE SIDED FAST EXIT FULL PACKAGE	PULSASYON , MANUEL YIKAMA TİPİ KAPALI DEVRE ELECTRONIC PULASTION, AUTOMATIC WASH WITH LACTOMETER (DIGITAL OR MANUEL)
STK-0056-1	2X18 TEK TARAFLI HIZLI ÇIKIŞ SAĞIM SİSTEMİ ORTA PAKET 2X18 ONE SIDED FAST EXIT EMPTY PACKAGE	ELEKTRONİK PULSASYON, OTOMATİK YIKAMA PULSATION, MANUAL WASH TYPE CLOSED CIRCUIT
STK-0056-2	2x18 TEK TARAFLI HIZLI ÇIKIŞ SAĞIM SİSTEMİ FULL PAKET 2x18 ONE SIDED FAST EXIT MEDIUM PACKAGE	ELEKTRONİK PULSASYON , OTOMATİK YIKAMA SÜT ÖLÇÜM SEÇENEĞİ DİJİTAL YADA MANUEL, SÜRÜ YÖNETİM ENTEGRASYONU ELECTRONIC PULASTION, AUTOMATIC WASH
STK-0057	2X20 TEK TARAFLI HIZLI ÇIKIŞ SAĞIM SİSTEMİ BOŞ PAKET 2X20 ONE SIDED FAST EXIT FULL PACKAGE	PULSASYON , MANUEL YIKAMA TİPİ KAPALI DEVRE ELECTRONIC PULASTION, AUTOMATIC WASH WITH LACTOMETER (DIGITAL OR MANUEL)
STK-0057-1	2X20 TEK TARAFLI HIZLI ÇIKIŞ SAĞIM SİSTEMİ ORTA PAKET 2X20 ONE SIDED FAST EXIT EMPTY PACKAGE	ELEKTRONİK PULSASYON, OTOMATİK YIKAMA PULSATION, MANUAL WASH TYPE CLOSED CIRCUIT
STK-0057-2	2x20 TEK TARAFLI HIZLI ÇIKIŞ SAĞIM SİSTEMİ FULL PAKET 2x20 ONE SIDED FAST EXIT MEDIUM PACKAGE	ELEKTRONİK PULSASYON , OTOMATİK YIKAMA SÜT ÖLÇÜM SEÇENEĞİ DİJİTAL YADA MANUEL, SÜRÜ YÖNETİM ENTEGRASYONU ELECTRONIC PULASTION, AUTOMATIC WASH

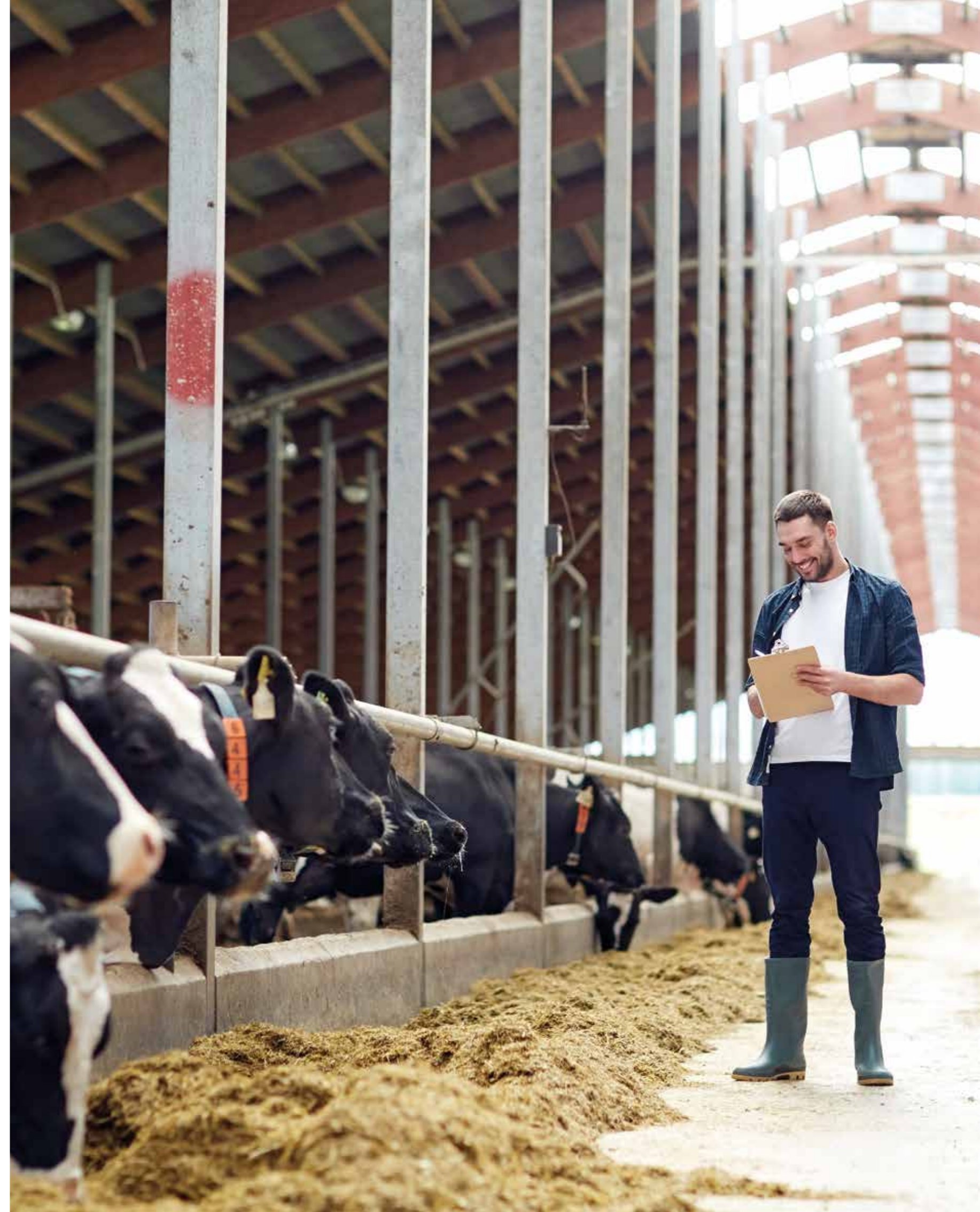



SÜRÜ YÖNETİMİ | HERD MANAGEMENT

Sürü Yönetim Sistemi Nedir?

Sürü yönetimi çiftlik içerisindeki bütün hayvanları ister tek ,tek isterseniz sürü halinde tek bir bilgisayar programı vasıtasıyla takip ve kontrol altına alabileceğiniz sistem verilerinizi anlık, aylık, yıllık olarak değerlendirebileceğiniz Sütakar sürü yönetim çalışma şema ve yapısı.

Süt verimi

Sağımhanede sağımı yapılan tüm hayvanların süt akış verilerin anlık haftalık aylık olarak kayıt altına alınması ve verimli verimsiz hayvanların belirlenmesinde çok önem oluşturmaktadır. Ayrıca işletme canlı hayvan satışında bir soy kütük verisi oluşturulması işletmedeki hayvanların kıymet ve değerlerine ulaşmasına yardımcı olmaktadır.

Kızgınlık

İşletme içerisinde bulunan hayvanların kızgınlık verilerin düzenli olarak tespit edilmesine imkan sağlamaktadır.

Böylece işletmelerde buzağı ve döl verim takip edilmesinde yardım sağlamakta çok faydalı olmaktadır.

Hayvanlar

İşletmede alınan ya da çıkarılan tüm hayvanların alış satış fiyatları, soy ağacının yüklenmesi, işletme içerinden mi dışarıdan mı hayvanların soy kütüğünün tutulması ve aynı zamanda bir hayvanın işletme de pedigrisini sağlamaktadır.

Raporlar

Bu sekmede yer alan hayvanların süt verimleri, maliyet girdi çıktıları, yem rasyon maliyetleri hakkında işletmeyi bilinçlendirmek ve kendi muhasebesini yapabilme imkanı sağlamaktadır.

Sağımhane

Bu linkte sağımhane içerisinde bulunan Sütakar elektronik süt ölçer ölçülerin programa entegre edilmesine imkan sağlamaktadır.

Yem yönetimi

Yem rasyon oluşturulması işletme içerisinde hayvan padok yapısına göre farklı beslenme eklenebilmesi ve maliyet girdileri ve hayvan başına ve kondisyonlarına göre program yapılmasına imkan sağlayarak işletmelere büyük avantaj sağlamaktadır.

Finans

Ahırda yapılan tüm masrafların, alış satış, deforme vb. gibi işletmelerin muhasebesini ve yıl olarak karlılık ve zararlılık analizlerini yapabilmesine olanak sağlamaktadır.

Ajanda

Aşı takvimi, veteriner kontrolleri hatırlatma, doğum takipleri, günlük haftalık ve aylık takip için işletmeler için hatırlatıcı olarak kullanılmakta iş akışı ve organizasyon ve iş akışı planlarını düzenlemek için fayda sağlamak amacı için tasarlanmıştır.

Duyurular

Sütakar sürü yönetim sistemi ana kullanıcı ve alt kullanıcı olarak tasarlanmıştır. Bu sekmede yönetim alt kademedeki kullanıcılar için yönlendirme ve talimatlar sekmesini kullanarak yönlendirme yapabilmektedir.

Sistem

Bu menü sadece yönetici tarafından görüntülenebilmektedir. Ayrıca alt kullanıcı zootechnik ya da veteriner sağımçı gibi alt basamaklar olarak sys2 sorunsuz veri beslemesi yapılarak en sorunsuz ve doğru çalışmasına yardımcı olmak için tasarlanmıştır.

Siz değerli kullanıcılarımız için verilerin sağlıklı olarak işletmelerin takip ve kontrol etmesine imkan sağlamaktadır.

What is Herd Management?

Herd management, all animals in the farm individually or With all the herd, you can follow up and control a computer program, evaluate your system data snapshot- monthly-yearly, Sütakar herd management study schema and structure.

Milk Efficiency

The milk flow data of all milking animals in the parlor recording on an instant-weekly-monthly basis and efficient-inefficient is very important in the determination of animals. In addition, the establishment of past log data in the sales of live animals helps the animals in the enterprise to reach their assets and values.

Agression

Anger data of animals in the establishment regularly allows detection.Thus, in the monitoring of calves and breedingis very useful in providing help.

Animals

Purchase prices of all animals purchased or sold in the enterprise, loading the genealogy, keeping the pedigree of the animals in and out of the facility, and at the same time providing the pedigree registration of an animal.

Reports

It provides the opportunity to provide information about the milk yields, costs, feed costs of animals in this tab and to make cost analysis.

Milking Parlour

This link contains Sütakar milk electronic milk meter in milking parlorit allows the measurements to be integrated into the program.

Feed Management

Feeding ration formation in animal paddock structure According to the different types of nutrition can be added to the cost formation, evaluation of the animal per condition and condition by providing the opportunity to provide a great advantage.

**Financial**

All costs made in the barn, buying-selling-deforming and so on. As it enables the accounting of enterprises and annual profit / loss analysis.

Calendar

Vaccination schedule and veterinary controls reminder, birth follow-ups, It is designed to be used as a reminder for businesses for daily weekly and monthly follow-up, and is intended for the purpose of providing benefits for organizing work flow plans and organization.

Announcements

Sütakar herd management system is designed as main user and downstream user. In this tab, management can direct the users in the lower tier by using the redirect and instructions tab.

System

This menu can only be viewed by the administrator. It is also designed to help the smoothest and most accurate operation of sys2 data without any downtime, such as sub-user zootechnic or veterinarian milking. For our valuable users, it allows the data to be monitored and controlled in a healthy way.

STK-0075

SÜRÜ YÖNETİM SİSTEMİ (SYS2) | LAND MANAGEMENT SYSTEM (SYS2)

SÜRÜ YÖNETİMİ SİSTEMİ EKLAN GÖRÜNTÜLERİ | HERD MANAGEMENT SYSTEM SCREENSHOTS

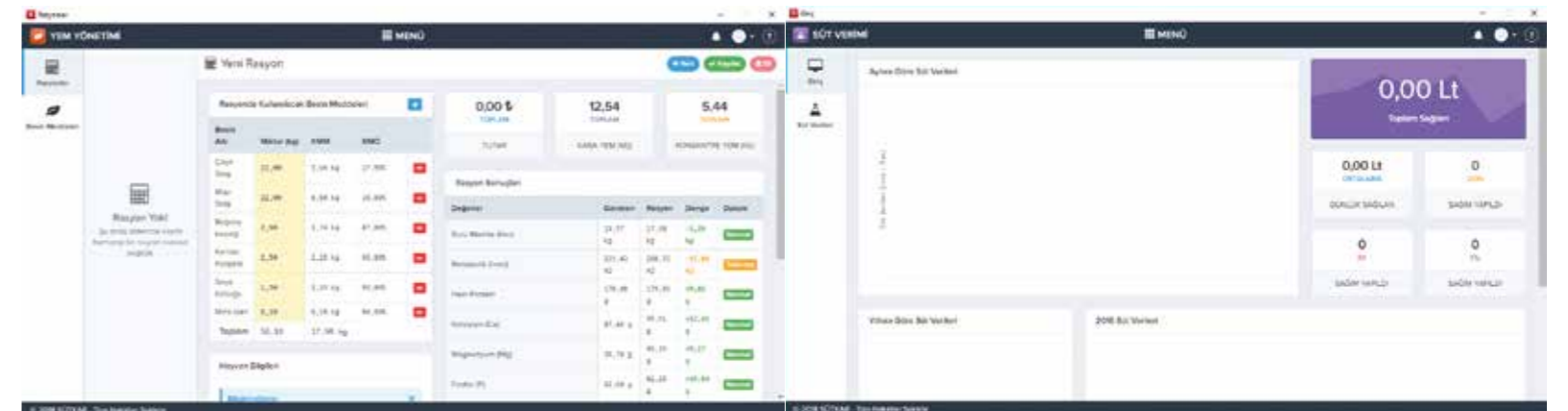



TANIMLAMA PEDOMETRE TRANSPONDER | DEFINING PEDOMETER TRANSPONDER

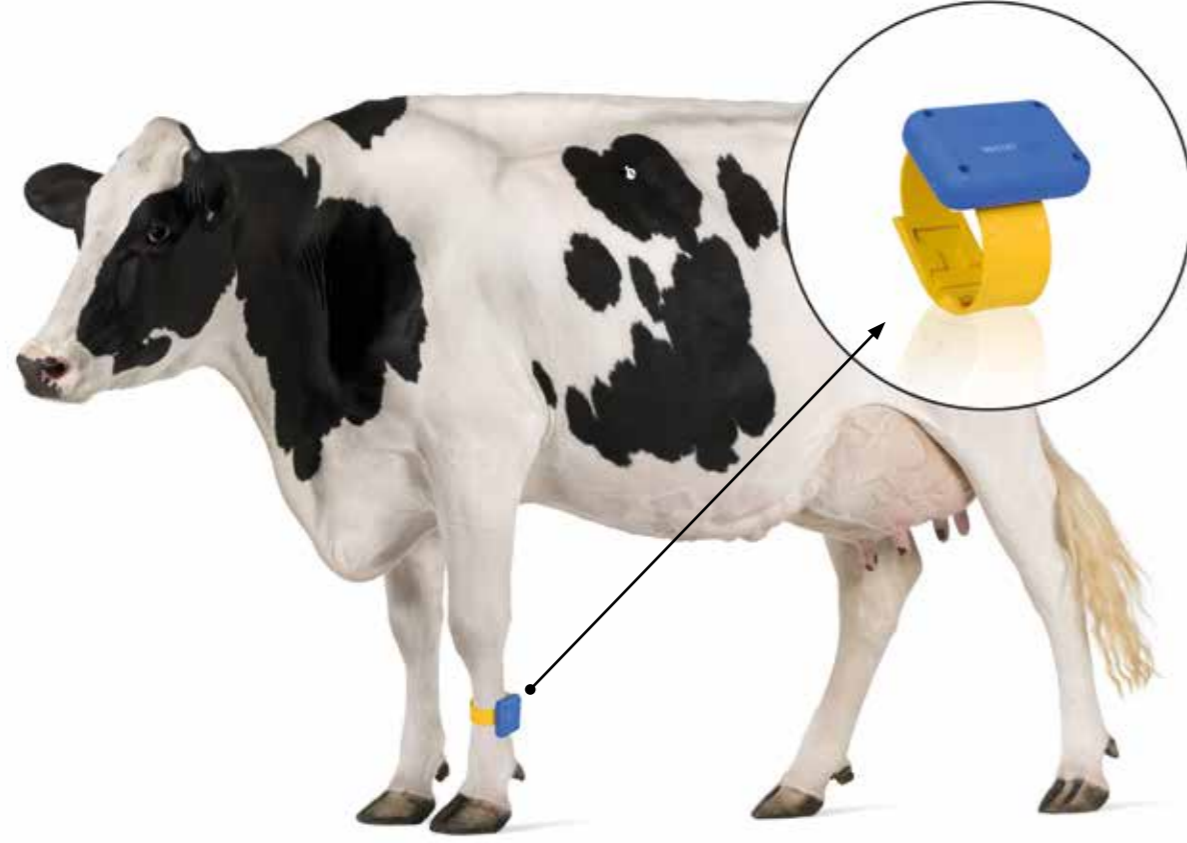

STK-0072 PEDOMETRE | PEDOMETER

STK-0073 PEDOMETRE KEMERİ | PEDOMETER BELT

STK-0074 HAYVAN TANIMLAMA | ANIMAL DEFINING

Tanımlama

Ahır içinde bulunan hayvanlara Sütakar tarafından üretilen alıcı antenler tarafından okunan ve sys aktarılan hayvanların tanımlanması bu hayvanların kayıt altında olmasına imkan sağlamaktadır.

Pedometre

Hayvanların hareketlerini pedometre kemeri ile ayaklarına montaj edilerek en doğru sonuçları elde etmek için hayvanların kızgınlıklarının belirlenmesinde önemli rol oynar doğru zamanda tohumlanarak hayvanların kızgınlık dönemlerinde aşılama zamanı belirlemede yardımcı olmaktadır.

Defining

The identification of animals read and transported by AACD to the animals contained in the barn by the receiver antennas produced by Sütakar allows these animals to be recorded.

Pedometer

It plays an important role in the determination of the anger of animals in order to obtain the most accurate results by assembling the movements of the animals with the pedometer belt. Seeding at the right time helps to determine the time of vaccination of animals during periods of anger.



ELEKTRONİK SÜT ÖLÇER | ELECTRONIC MILK METER



Elektronik süt ölçer sağımı yapılan hayvanların bir kaptan toplama elektronik sıvı ölçümleme ile Sütakar süt ölçer paneline aktarılıp dijital olarak ekrana yansıtılmasına imkan sağlamaktadır. Süt ölçümünde hata payı en aza indirilmiştir.

Aynı zamanda kontrol panelinden otomatik başlık çıkarıcı ayarlama pulsasyon ayar değiştirme imkanları da sunulmaktadır.

Süt ölçer ve otomatik başlık çıkarıcı sürü yönetiminden ayrı ve beraber olarak da sizlerin hizmetine sunulmaktadır.

The electronic milk meter allows the milking of animals to be collected in a container by electronic liquid metering and transferred to the Sütakar milk meter panel and digitally reflected to the screen. The margin of error in milk measurement is minimized.

At the same time control panel enables us edit the settings of automatic header remover and pulsation.

Milk meter and automatic header remover could work together or could work alone.



KEÇİ VE KOYUN SAĞIM SİSTEMLERİ | GOAT AND SHEEP MILKING SYSTEMS

Yıllar boyu hayvan yetiştiriciliği yapan ve bu konuda sürdürdüğü araştırma ve geliştirme faaliyetlerinin sonucunda SÜTKAR; küçük sağmallarında etkin ve verimli bir şekilde sağılması için yeni yüksek performanslı ürünlerle küçükbaş sağım ünite grubunu dizayn etmiştir.

Bu ürün grupları profesyonel sağımcıların ihtiyaçlarını karşılamak üzere geliştirilmiştir.

Hızlı çıkış sistemler.
Pnomatik yemlik sistemleri.
Ergonomik sağım.
Gelişmiş sağım başlığı performansı.
Vakum seviyesinde düzenlilik.
Kullanım kolaylığı.
Meme sağlığı koruma.
Sürü yönetim sistemi entegrasyonu.

SÜTKAR, as a result of research and development activities carried out by animal breeding for many years; designed a group of small ruminant milking units consisting of new high-performance products for efficient and efficient milking in small milkings.

These product groups have been developed to meet the needs of professional milkers.

*Fast output systems.
Pneumatic feed systems.
Ergonomic milking.
Improved milking performance.
Regularity at the vacuum level.
Ease of Use.
Breast health protection.
Herd management system integration.*





SAĞIMHANE OTOMATİK YIKAMA SİSTEMİ | MILKING PARLOUR AUTOMATIC WASHING SYSTEMS

Sağım makinesinde bakteri oluşumunu en aza indirmek aynı zamanda süt kalitesini en yüksek oranlara çıkarmak için günlük ve haftalık yıkama seçenekleri ve aynı zamanda durulama süresi ayarları ile sorunsuz kullanım için SütKar kalite ve güvencesi ile siz değerli kullanıcılarımız hizmetine sunmaktayız.

In order to minimize the bacteria formation in milking machine and also to increase the milk quality to the highest rates, we offer the quality and safety of ERHAN quality to our valuable users with daily and weekly washing and rinse time setting options without any problems.



STK-0076

SAĞIMHANE OTOMATİK YIKAMA SİSTEMİ



GÜBRE YÖNETİMİ SİSTEMLERİ MANURE MANAGEMENT SYSTEM

Süt ve besi çiftliklerinde, hayvan dışkısının önce ahırlardan uzaklaştırılması sonrada doğaya uygun olarak bertarafını sağlayan sistemlerin bütüne "Gübre yönetimi" denir. Gübre çukurları, gübre pompaları, sıyırıcılar, gübre karıştırıcı ekipmanlar, separatörler, gübre tankerleri ve gübre dağıtıcı sistemler "Gübre Yönetiminin" temel elemanlarıdır.

In dairy and fattening farms, the systems that provide the disposal of animal faeces in accordance with the nature after the removal of the stool from the stables are called is Manure management Süt. Manure pits, Manure pumps, scrapers, Manure mixers, separators, Manure tankers and Manure spreaders are the basic elements of s Manure Management G.



GÜBRE YÖNETİMİ | MANURE MANAGEMENT

Süt ve et üreten çiftlikler için; gübre yönetimi ve hayvan konforunu sağlayan ağır ekipmanlarını her çiftlik boyutuna uygun, ağır kullanım şartları için dayanıklı, gelişmiş ürünler üretmekteyiz. SÜTKAR olarak çiftlik ekipmanları kategorisi altında, yüksek kaliteli yemlik kilitleri, yatak durak demir setleri, hayvan fırçası, donmaz suluk, travay, havalandırma fanları, gübre sıyırıcılar, gübre pompası, karıştırma makinesi ve seperatörü, buzağı kulübesi, yem kırma-karma-dağıtma makine ve römorkları, revir ve doğumhane ekipmanları, dezenfektan ve ileri teknoloji sürü yönetim sistemlerini üreticinin kullanımına sunuyoruz.

Süt üretimi kadar gübre yönetimine de önem veren Sütgar, anahtar teslim çiftlik uygulamalarında makine ekipman parkını projelendiriyor, hayvan sağlığı ve konforunu ön planda tutan ekipmanlarla yüksek verimli tesisleri ekonomiye kazandırıyor.

Süt ve besi çiftliklerinde, hayvan dışkısının önce ahırlardan uzaklaştırılması hayvan sağlık ve hijyeni için büyük önem arz etmektedir. Bu süreç ile başlayan ve depolama (gübre çukuru, gübre karıştırma , gübre sepere edilmesi) ve yönlendirilmesi ile devam eden sistemin tamamıdır.

GÜBRE SIYIRICI | MANURE STRIPPER

Gübrenin doğru bir şekilde ahırın içinden sıyırılması ve uygun yerde depolanması gübre yönetiminin ilk adımdır.

For dairy and meat producing farms; We produce manure management and animal comfort equipment that are suitable for every farm size and durable for tough use conditions. In Sutkar, under the category of farm equipment, high quality manger locks, bed stall iron sets, animal brush, frostless drinker, travay, ventilation fans, Manure scrapers, Manure pump, mixing machine and separator, calf kennel, feed crushing-mixed-dispensing machinery and trailers, infirmary and delivery room equipment, disinfectant and offer advanced technology management systems.

Sütgar, which gives importance to manure management as well as milk production, designs machinery equipment park in turn-key farm applications and brings high-efficiency facilities to economy with equipment that prioritizes animal health and comfort.

In dairy and fattening farms, the removal of animal faeces from the stables is of great importance for animal health and hygiene. It is the complete system that starts with this process and continues with storage (Manure pit, Manure mixing, Manure sorting) and directing.

It is the first step of manure management that stripping manure and storing it in a good place.

STK-0058 GÜBRE SIYIRICI TEK YOLLU | MANURE STRIPPER ONE WAY

STK-0059 GÜBRE SIYIRICI ÇİFT YOLLU | MANURE STRIPPER DOUBLE WAY



GÜBRE POMPASI | MANURE PUMP

Gübre pompası çukur içinde homojen bir yoğunluğa gelmiş gübrenin sıvı gübreyi transfer aracına yada seperatöre yönlendirerek tarlaya gönderilmesi ve ekolojik organik zincirin başlaması ve aynı zamanda ürünleri organik olarak yetiştirilip üretilmesi için çok önem taşımaktadır.

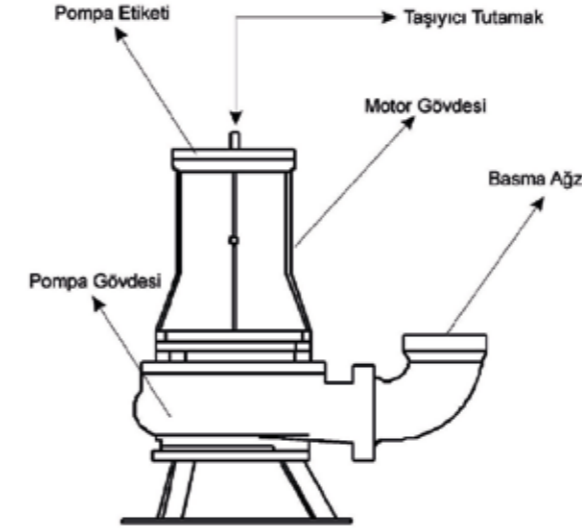

The Manure Pump is very important for the fertilization of the manure which has reached a homogeneous density in the pit by directing the liquid manure to the transfer vehicle or the seperator and to start the ecological organic chain and at the same time to grow and produce the products organically, seperator in order to start ecological organic loop.



STK-0061 11 KW

STK-0061-1 7,5 KW

STK-0061-2 5,5 KW

STK-0061-3 3,5 KW

GÜBRE KARIŞTIRICI | MANURE MIXER

Gübre sıyırıcı aracılığı ile gübre çukuruna sevk edilen gübrelerin gübre çukuru içerisinde parçalanması ve gübre pompasının rahat çalışması için büyük önem taşımaktadır.

Manure sent to the manure pit by the Manure Scraper is very important in the manure pit, its disintegration and convenient operation of the manure



STK-0060 GÜBRE KARIŞTIRICI | MANURE MIXER



GÜBRE SEPERATÖRÜ | MANURE SEPERATOR

Doğru bir şekilde ıslah edilen gübre ile transfer maliyetleri ve depolama koşullarını iyileştirecektir.

Gübre çukurundaki yoğun sıvılıktaki gübreyi separe ederek katı ile sıvı ayrımını doğru yapmakta katı gübrede kuruluk ayarı yapabilmeyi sağlamakta ve işletmelere ek kazançlar sağlayarak işletmelere fayda sağlamaktadır.

Properly improved fertilizer will improve transfer costs and storage conditions. By separating the fertilizer from the dense liquid in the fertilizer pit, you can make the separation between the solid and the liquid correctly and enable you to adjust the dryness in the solid fertilizer. provides financial gain benefits to enterprises.



STK-0062

GÜBRE SEPERATÖRÜ | MANURE SEPERATOR



HAYVAN KONFORU SİSTEMLERİ ANIMAL COMFORT SYSTEMS



HAYVAN FIRÇASI | ANIMAL BRUSH

Mafsalı olarak Sütkar tarafından patentli olarak üretilen hayvan kaşıma fırçası mevcut komut kartlarını ekale ederek farklı bir algoritma ile çalışmakta aynı zamanda üzerinde kullanılan tahrik motoru 220 Volt elektrik motoru çalışmakta işletmelerin kırsal kesimlerde bulunmasından dolayı elektrik voltaj dengesizlikleri sebebi ile motor düşük voltaj 110 volt ya da yüksek voltaj 250 volta kadar sorunsuz ve problemsiz çalışabilme özelliğine sahiptir. Aynı zamanda fırça tasarımı da hayvanların her bölgesine temas edebilmektedir.

- Kaşıma Fırçasının Avantajları
- Hayvanların tüy atım dönemlerinde stresten uzaklaşmalarını ve et ve süt kaybını azaltılmasına yardımcı olmaktadır.
- Hayvanlara masaj yaparak süt ve verim artışı sağlamaktadır.

Sütkar patented Animal Scratching Brush works with a different algorithm by balancing existing command cards. Over 220 volt electric motor running. Due to the electrical voltage imbalances resulting from the presence of rural enterprises, the motor has a low voltage between 110 volts and high voltages of 250 volts. At the same time, the brush design is able to contact all parts of the animals.

- Advantages of Scratching Brush
- It helps animals to move away from stress and reduce meat and milk loss during feathering periods.
- Provides milk and yield increase by massaging animals.



STK-0080 HAYVAN KAŞIMA FIRÇASI | ANIMAL BRUSH



YEMLİK KİLİT SETİ | CRIB LOCK SET

Yatak setler Ø60, yemlik kilit setleri Ø48 ve Ø60'lık borulardan imal edilmektedir. Sıcak daldırma galvaniz kaplamadır. Modüler ve ayarlanabilir sistemlidir. 2 yıl garantilidir.

Yemlik kilitleri hayvanların düzenli zamanlarda ve istenilen miktarlarda beslenmelerini sağlar. Tek bir kolla kilitler kolayca açılıp kapatılabilir. Genç ve yetişkin ineklerin dengeli beslenmesi için tasarlanmıştır.

- Hayvan beslenmesinde eşitlik ve adetli bir beslenme konusunda kesin çözüm üretir.
- Aynı zamanda veteriner çalışmalarını kolaylaştırır.
- Çift yönlü açılabilme özelliği ile hayvanlara bireysel komut özelliği sağlar.
- Boynuz yakım, kesim ve söküm işleri için ise Sütkar yemlik kilitleri avantaj sağlamaktadır.

The bearing sets Ø60 are made of Ø48 and Ø60 pipes with feeding lock sets. Hot dip galvanizing, modular and adjustable system. 2 years warranty.

Feeder locks allow animals to be fed at regular times and in desired quantities. With a single lever, the locks can be easily opened and closed. Designed for a balanced diet of young and adult cows.

- It produces the exact solution for equality and number of nutrition in animal nutrition
- It simplifies the work of veterinary at the same time
- It provides individual command feature to the animals with its bidirectional opening feature.
- Individual command to animals with bidirectional opening feature is important on crib lock set.

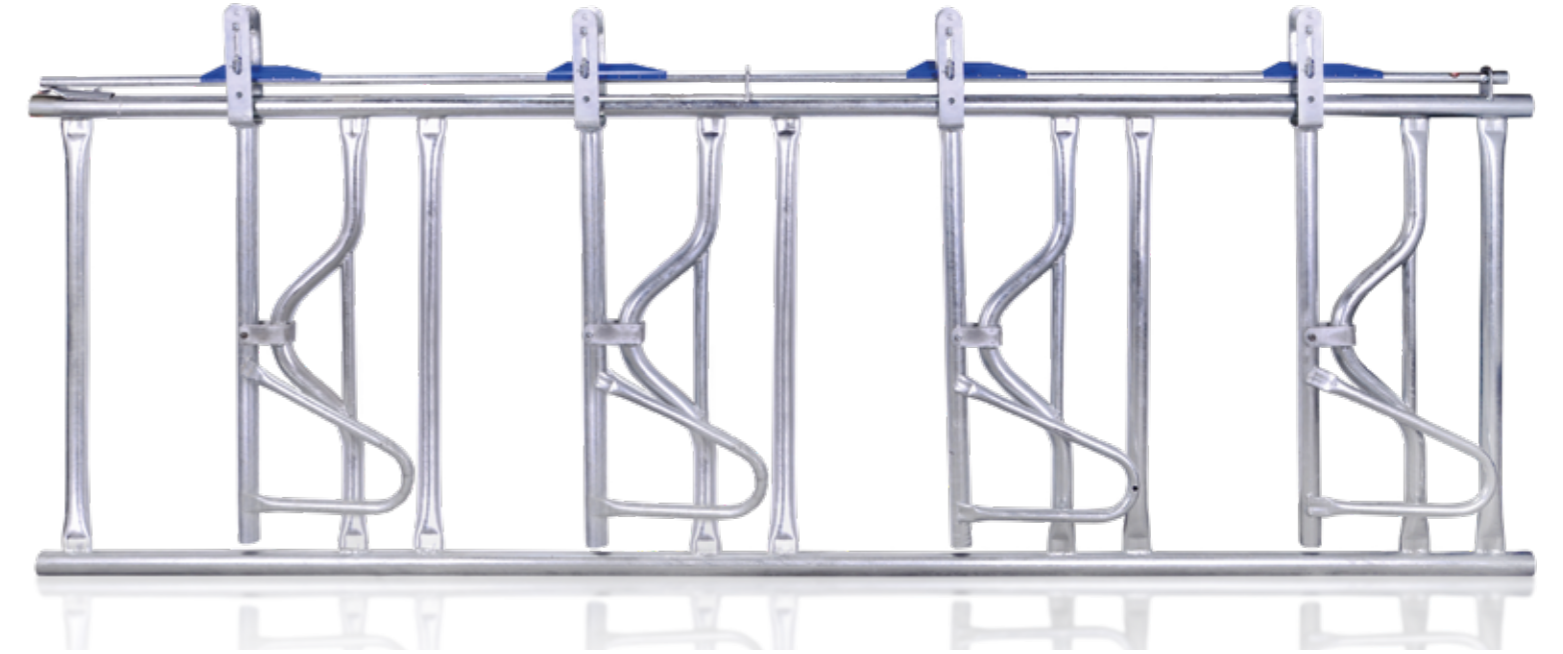

STK-0077-1 Ø48 x 3mm

STK-0077-2 Ø60 x 3mm



BUZAĞI MAMA HAZIRLAMA MAKİNASI | CALF FEEDING TROLLEY SYSTEM

Buzağı ölümlerinin önüne geçebilmek için süt kar arge çalışması ile sizlerin hizmetine sunmuştur.

Çift cidarlı olması cidar aralarında sıvı olarak su kullanılması ve suyun sıcaklığı ile sütün ya da mamanın ısıtılması sonucu süt ve mamadaki vitaminlerin yakılarak kaybedilmeden ayrıca özel pano dizaynı ile ısıtılan ürünün aynı derecede stabil tutulması da ürüne ayrı bir ayrıcalık katması ile buzağılara emilim yapılması ve bağırsak yapısı ve sağlığı koruma altına alınmaktadır. Sağlıklı ve neşeli buzağı yetiştirilmesi için de ayrıca mobil olması neticesi ile makinemizin gezdirilmesi de mümkündür.

To prevent calf deaths, Erhan R & D has presented to you.

Double-walled water between the walls of the water and the temperature of the water and milk or milk as a result of heating of the milk and food in the vitamins are burned without losing the burned product with the special panel design of the same degree of stability of the product with the addition of a special privilege to absorb the calves and intestine structure health is protected. It is also possible for the healthy and cheerful calf to be grown and it is also possible to roam our machine.



STK-0022	50 LT MAMA MAKİNESİ - SÜT ISITICI 50 LT FEED MACHINE - MILK HEATER
STK-0023	100 LT MAMA MAKİNESİ - SÜT ISITICI 100 LT FEED MACHINE - MILK HEATER
STK-0024	150 LT MAMA MAKİNESİ - SÜT ISITICI 150 LT FEED MACHINE - MILK HEATER
STK-0025	200 LT MAMA MAKİNESİ - SÜT ISITICI 200 LT FEED MACHINE - MILK HEATER



YATAK DURAK DEMİR SETİ | IRON REST STATION SET

Ahır içerisindeki hayvanların istirahati için tasarlanmış olan ürünlerimiz aynı zamanda meme sağlığı ve rahim iltihaplanmasını en aza indirmek ve bakterili ortamlarda uzak tutmak için tasarlanmıştır.

Bu ürünün imalatında galvanizli demirden imal edilmiş olması ahır içerisindeki asit nedeni ile korozyona uğramasının önüne geçmiş olduk.

Our products for resting animals in the barn are also designed to minimize nipple and uterine inflammation and to keep them away from bacteria.

With this product made of galvanized iron, we prevented the corrosion of the iron due to the acid in the barn.



STK-0078 Ø48 x 3mm

STK-0078-1 Ø60 x 3mm

HAYVAN ALTI YATAĞI | ANIMAL BED

Hayvan yatağı kauçuktan imal edilerek işletmelerin hizmetine sunulmuştur.

Animal bed made of rubber and serviced to the service of enterprises

Hayvan Yatağının Faydaları

- Yatak üzerinde yatan hayvanların sıcak ve soğuktan etkilenmeden vücut sıcaklığı ile rahat ve konforlu istirahat süreleri geçirmelerini sağlamak
- Ayrıca yatakta istirahat eden hayvanların hijyenik bir ortamda bulunmalarına yardımcı olmaktadır.

Advantages of Animal Bed

- Ensuring that the animals lying on the bed have comfortable and comfortable resting times with body temperature without being affected by hot and cold.
- Also helps bed rest animals to be found in a hygienic environment.





DONMAZ SULUK | FROST-PROOF DRINKING BOWL

Donmaz suluğun özellikleri:

- Temizliği çok kolaydır
- Termostatik yapısı ile 365 gün şebeke suyunu aynı sıcaklıkta tutar.
- Şamandıra koruma sistemi mevcut olup şamandıra arızası hiç yok denecek kadardır.
- Hayvanlarınız bol ve sağlıklı su içerler, bilindiği gibi su içmeyen hayvan süt veremez.
- 9 bar'a dayanıklı tesisat bağlantı ekipmanı ile bağlantı yapılır.
- Hayvan sağlığına zarar verebilecek materyaller bulunmamaktadır
- Donmaz suluk takribi 30-40 hayvana hitap etmektedir.

Features of Frost-Proof Drinking Bowl

- TEasy to Clean
- With its thermostatic structure, it keeps the mains water at the same temperature for 365 days.
- There is a float protection system that its failure is almost non-existent.
- Your animals drink plenty and healthy water.
- Connection is made with 9 bar-resistant installation equipment.
- There are no materials that may harm animal health.
- It feeds about 30-40 animals



STK-0330

ÇİFT TOPLU HAYVAN DONMAZ SULUĞU
DOUBLE BALL FROST-PROOF DRINKING BOWL



STK-0329

TEK TOPLU DONMAZ SULUK
ONE BALL FROST-PROOF DRINKING BOWL

DEVİRMELİ SULUK | OVER DRINKING BOWL



STK-0332

KROM DEVİRMELİ SULUK | CHROMIUM TILT-OVER DRINKING BOWL

- A ısı 304 kromdan imal edilmektedir. Ahır içerisinde konumlandırılmaktadır.
- Litre hacimleri 100 lt, 150 lt, 200 lt olarak üretilmekte duvar tipi devirmeli; ayaklı olarak (sabit ,devirmeli) seçenekleri mevcuttur.
- Ayrıca şamandıralı olduğu için otomatik olarak su seviyesini kendisi ayarlamakta krom yüzey olduğu için ise temizliğin daha kolay yapılabilmesini sağlamaktadır.

- A heat is made of 304 chrome. Positioning in the barn.
- Liter volumes are produced as 100 lt, 150 lt, 200 lt. Wall type tilting; available with stand (fixed, tilt).
- Because it is float so it also automatically adjusts the water level. The surface is made of chromium, making cleaning easier.



DÖKÜM SULUK | CASTING DRINKING BOWL

- A ısı 304 kromdan imal edilmektedir.
- Ahır içerisinde konumlandırılmaktadır.
- Litre hacimleri 100 lt, 150 lt, 200 lt olarak üretilmekte duvar tipi devirmeli; ayaklı olarak (sabit ,devirmeli) seçenekleri mevcuttur.
- Ayrıca şamandıralı olduğu için otomatik olarak su seviyesini kendisi ayarlamakta krom yüzey olduğu için ise temizliğin daha kolay yapılabilmesini sağlamaktadır.

- A heat is made of 304 chrome
- Positioning in the barn.
- Liter volumes are produced as 100 lt, 150 lt, 200 lt. Wall type tilting; available with stand (fixed, tilt).Wall type tilting; available with stand (fixed, tilt)
- Because it is float so it also automatically adjusts the water level. The surface is made of chromium, making cleaning easier.



STK-0331

DÖKÜM SULUK | CASTING DRINKING BOWL

BUZAĞI KULÜBESİ | CALF COTTAGE

Yeni doğan buzağuların hastalıklara ve diğer mikrobiyel organizmalara karşı bağışıklık ve direnç kazanması ilk 5 ila 7 haftalık dönem içerisinde gerçekleşir. Bu zaman zarfı içerisinde buzağular dışarıdan gelecek olan mikrop ve hastalıklara karşı savunmasız olduğundan akciğer, ishal vb. hastalıklara yakalanabilirler. Bunun sonucu olarak da %20 ila %30 oranında yaşamsal bir kayıp da görülebilmektedir.

New-born calves have acquired immunity and resistance to diseases and other microbial organisms in the first 5 to 7 weeks. Within this time period, calves are vulnerable to microbes and diseases that come from outside, and they can be infected with diseases such as lung disease and intestinal infections. As a result, a 20% to 30% loss of life can also be observed.



STK-0079

BUZAĞI KULÜBESİ | CALF COTTAGE



SOĞUTMA TANKLARI

COOLING TANK



2BI DeneY Raporuna sahip st soĐutma tanklarımız stn saĐıldıktan hemen sonra +4 C deki saklama sıcaklıĐına hızla dŐrlmesi ve bu sıcaklıkta saklanması ile zararlı bakterilerin remesi durdurulur.

Stn soĐutulması, kaliteli stn elde edilip en yksek fiyata satılması iin tek yoldur. Stn soĐutulması sırasında en kritik nokta olan +10 C ye dŐrlmesine kadar geen srede bakteri remesi devam edecektir. Bu sre ne kadar kısa olursa bakteri sayısı o kadar az olacaktır. Stkar soĐutma tanklarının 300 kg ile 10 ton arasında eŐitleri mevcuttur. reticinin ihtiyaına en uygun soĐutma ve n soĐutma sistemleri saĐım sisteminin iŐleyiŐ tarzına uygun imal edilmektedir. Otomatik yıkama teknolojisi ile her santimetre-kare yzey alanı aynı ve yeterli miktarda temizleyici sıvının temas etmesi saĐlanmıŐtır.

Our milk cooling tanks with 2BI Test Report will rapidly reduce the storage temperature at +4 C immediately after milking. In this way, the growth of bacteria is stopped.

Cooling of milk is the only way to obtain quality milk and be sold at the highest price. Most important part of cooling the time during the operation. The shorter this time means the smaller the number of bacteria. 300 kg to 10 tons of cooling tanks available in Stkar. It has automatic washing system.

YATAY SOĐUTMA TANKLARI | HORIZONTAL COOLING TANK

Yatay SoĐutma Tankı Hacimleri | Horizontal Cooling Tank Volumes

RN KODU PRODUCT CODE	STK-0017-1	STK-0018	STK-0019	STK-0020	STK-0021
KAPASİTE CAPACITY	2000 lt	3000 lt	4000 lt	5000 lt	6000 lt

rnlerimizde 2BI Normlarına uygun retilmektedir. AISI 304 Paslanmaz elikten retilmektedir.

Our products are produced in accordance with 2BI Norms. Manufactured from AISI 304 stainless steel.



DİKEY SOĐUTMA TANKLARI | VERTICAL COOLING TANK

Dikey SoĐutma Tankı Hacimleri | Vertical Cooling Tank Volumes

RN KODU PRODUCT CODE	STK-0011	STK-0012	STK-0013	STK-0014	STK-0015	STK-0016	STK-0017
KAPASİTE CAPACITY	200 lt	300 lt	500 lt	750 lt	1000 lt	1500 lt	2000 lt

rnlerimizde 2BI Normlarına uygun retilmektedir. AISI 304 Paslanmaz elikten retilmektedir.

Our products are produced in accordance with 2BI Norms. Manufactured from AISI 304 stainless steel.



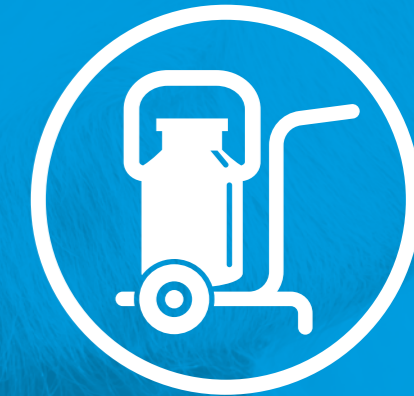

MOBİL SÜT SAĞIM MAKİNALARI MOBILE MILKING MACHINE

Süt sağımında da makine kullanımı hem hijyen ve hayvan sağlığı hem de zaman kazanımı açısından önem arz etmektedir. Bunun yanında kaliteli bir süt ancak sağlıklı hayvanlardan, temiz bir sağım sonucu elde edilir. Memelerin sağlıklı olması temizlik kurallarına uymaktan geçer. Sütçülük yapılan bir işletmede temel konu temizlik olmalıdır. Hayvan barınaklarının süpürülüp yıkanması, dezenfekte edilmesi, sağımcinin el ve vücut sağlığının yerinde olması, kolayca yıkanıp temizlenen temiz iş kıyafetleri bulunması gerekmektedir.

Using machines at milking is important for hygiene, animal health and time. In addition, a quality milk can be obtained from healthy animals with good milking. The health of the breasts is about the rules of cleaning. The main issue in a dairy farm should be cleaning. It is important that animal shelters be swept, disinfected, milker hand and body health is good, and we have work clothes are easily washed and cleaned.



Çok değişik tipte sağım makineleri olmasına rağmen hepsi aynı esasa göre çalışırlar. Bir sağım makinesinde beş temel kısım bulunmaktadır:

1. Vakum motoru,
2. Vakumu taşıyan borular,
3. Pulsatör,
4. Sağım ünitesi,
5. Sütün toplandığı yer.

Makineli sağım ile süt 5-10 dak. içinde sağılabilir. Sağım sonuna doğru süt azaldıkça memelere avuç içi ile masaj yapmak yararlıdır. Sütün tamamının memeden alınmasına özen gösterilmelidir.

Although there are many different types of milking machines they work generally same. There are five basic parts in a milking machine

1. Vacuum motor,
2. Vacuum bearing pipes,
3. Pulsator,
4. Milking unit,
5. Milk Collection Area

Milk can be delivered in 5-10 minutes with machine milking. It is useful to massage the breasts with palms when milk decreases towards the end of milking. It is important to get milk from completely breasts.

2-PULSATÖR | PULSATOR

Vakumla çalışan pulsatör elektrik güç kaynaklarından bağımsızdır. Nabız hızı istenildiğinde ayarlanabilir.
Operated pulsator is independent of electrical power sources
The pulse rate can be adjusted.

3-VAKUM POMPASI | VACUUM PUMP

SütKar vakum üniteleri dayanıklı ve az bakım gerektirir. Sessiz, tamamen yağsız son derece güvenli olup çevre dostudur.
The maintenance units of SütKar require less maintenance.

1-SAĞIM BAŞLIĞI | MILKING HEADER

6-SÜT HORTUMU MILK HOSE

4-GÜĞÜM | CHURN

SütKar mobil makina güğümleri, tek parça kaynaklı gövdeye ve kolay taşınabilirlik için güçlü kollara sahiptir. Performanslı ve uzun ömürlü kullanım sağlar.
SütKar's mobile machine churns have a single-part welded body and strong arms for easy portability.

5-VAKUM TANKI | VACUUM TANK



STK-0001

MOBİL ÇİFT SAĞIMLI KROM GÜĞÜMLÜ YAĞLI SÜT SAĞIM MAKİNASI MOBILE DOUBLE MILKING CHROMIUM CHURN FAT MILK MILKING MACHINE



TEKNİK ÖZELLİKLERİ | TECHNICAL SPECIFICATIONS

Bağımsız elektrik motoru, pulsatör, pençe, memelik ve aksesuarları
Independent electric motor, pulsator, claw, nozzle and accessories

KAPASİTESİ CAPACITY	2x10 - 12 İnek Sağım 2x10 - 12 Cow
PULSATÖR PULSATOR	60/40 SütKar Pnömatik 60/40 SütKar Pneumatic
ŞALTER BREAKER	16 A.V. Otomat Topraklı 16 A.V. Otomat Grounded
MOTOR GÜCÜ Monofaze Elektrik Motoru ENGINE POWER Single phase electric	0.75 hp 0.55 kw 1420 dev./dk. 0.75 hp 0.55 kw 1420 rev./min.
POMPA DEBİSİ PUMP FLOW	250 lt/dk. Yağlı Fiber Paletli 250lt/dk.Oiled Fiber Crawler



STK-0002

MOBİL ÇİFT SAĞIMLI ALÜMİNYUM GÜĞÜMLÜ YAĞLI SÜT SAĞIM MAKİNASI MOBILE DOUBLE MILKING ALUMINIUM CHURN FAT MILK MILKING MACHINE

TEKNİK ÖZELLİKLERİ | TECHNICAL SPECIFICATIONS

Bağımsız elektrik motoru, pulsatör, pençe, memelik ve aksesuarları
Independent electric motor, pulsator, claw, nozzle and accessories

KAPASİTESİ CAPACITY	2x10 - 12 İnek Sağım 2x10 - 12 Cow
PULSATÖR PULSATOR	60/40 SütKar Pnömatik 60/40 SütKar Pneumatic
ŞALTER BREAKER	16 A.V. Otomat Topraklı 16 A.V. Otomat Grounded
MOTOR GÜCÜ Monofaze Elektrik Motoru ENGINE POWER Single phase electric	0.75 hp 0.55 kw 1420 dev./dk. 0.75 hp 0.55 kw 1420 rev./min.
POMPA DEBİSİ PUMP FLOW	250 lt/dk. Yağlı Fiber Paletli 250lt/dk.Oiled Fiber Crawler





STK-0003

MOBİL ÇİFT SAĞIMLI ÇİFT KROM GÜĞÜMLÜ YAĞLI SÜT SAĞIM MAKİNASI
MOBILE DOUBLE-DOUBLE CHROMIUM GRASS MILKING MACHINE

STK-0004

MOBİL ÇİFT SAĞIMLI ÇİFT ALÜMİNYUM GÜĞÜMLÜ YAĞLI SÜT SAĞIM MAKİNASI
MOBILE DOUBLE SIDED DOUBLE ALUMINUM TREADED MILKING MACHINE



TEKNİK ÖZELLİKLERİ | TECHNICAL SPECIFICATIONS

Bağımsız elektrik motoru, pulsatör, pençe, memelik ve aksesuarları
Independent electric motor, pulsator, claw, nozzle and accessories

KAPASİTESİ CAPACITY	2x10 - 12 İnek Sağım 2x10 -1 2 Cow
PULSATÖR PULSATOR	60/40 SütKar Pnömatik 60/40 SütKar Pneumatic
ŞALTER BREAKE	16 A.V. Otomat Topraklı 16 A.V. Otomat Grounded
MOTOR GÜCÜ Monofaze Elektrik Motoru ENGINE POWER Single phase electric	0.75 hp 0.55 kw 1420 dev./dk. 0.75 hp 0.55 kw 1420 dev./min.
POMPA DEBİSİ PUMP FLOW	250 lt/dk. Yağlı Fiber Paletli 250lt/dk.Oiled Fiber Crawler



STK-0007

MOBİL ÇİFT SAĞIMLI ÇİFT KROM GÜĞÜMLÜ KURU SÜT SAĞIM MAKİNASI
MOBILE DOUBLE-DOUBLE CHROME STEEL DRIED MILKING MACHINE



TEKNİK ÖZELLİKLERİ | TECHNICAL SPECIFICATIONS

Bağımsız elektrik motoru, pulsatör, pençe, memelik ve aksesuarları
Independent electric motor, pulsator, claw, nozzle and accessories

KAPASİTESİ CAPACITY	2x10 - 12 İnek Sağım 2x10 -1 2 Cow
PULSATÖR PULSATOR	60/40 SütKar Pnömatik 60/40 SütKar Pneumatic
ŞALTER BREAKE	16 A.V. Otomat Topraklı 16 A.V. Otomat Grounded
MOTOR GÜCÜ Monofaze Elektrik Motoru ENGINE POWER Single phase electric	0.75 hp 0.55 kw 1420 dev./dk. 0.75 hp 0.55 kw 1420 dev./min.
POMPA DEBİSİ PUMP FLOW	250 lt/dk. Kuru Kömür Paletli 250 l/min. Dry Coal Crawler



STK-0005

MOBİL ÇİFT SAĞIMLI KROM GÜĞÜMLÜ KURU SÜT SAĞIM MAKİNASI
MOBILE DOUBLE MILKING CHROMIUM CHURN DRY MILK MILKING MACHINE

STK-0006

MOBİL ÇİFT SAĞIMLI ALÜMİNYUM GÜĞÜMLÜ KURU SÜT SAĞIM MAKİNASI
MOBILE DOUBLE MILKING ALUMINIUM CHURN DRY MILK MILKING MACHINE

TEKNİK ÖZELLİKLERİ | TECHNICAL SPECIFICATIONS

Bağımsız elektrik motoru, pulsatör, pençe, memelik ve aksesuarları
Independent electric motor, pulsator, claw, nozzle and accessories

KAPASİTESİ CAPACITY	2x10 - 12 İnek Sağım 2x10 -1 2 Cow
PULSATÖR PULSATOR	60/40 SütKar Pnömatik 60/40 SütKar Pneumatic
ŞALTER BREAKE	16 A.V. Otomat Topraklı 16 A.V. Otomat Grounded
MOTOR GÜCÜ Monofaze Elektrik Motoru ENGINE POWER Single phase electric	0.75 hp 0.55 kw 1420 dev./dk. 0.75 hp 0.55 kw 1420 dev./min.
POMPA DEBİSİ PUMP FLOW	250 lt/dk. Kuru Kömür Paletli 250 l/min. Dry Coal Crawler



STK-0008

MOBİL ÇİFT SAĞIMLI ÇİFT ALÜMİNYUM GÜĞÜMLÜ KURU SÜT SAĞIM MAKİNASI
MOBILE DOUBLE MILKING DOUBLE ALUMINIUM CHURN DRY MILK MILKING MACHINE

TEKNİK ÖZELLİKLERİ | TECHNICAL SPECIFICATIONS

Bağımsız elektrik motoru, pulsatör, pençe, memelik ve aksesuarları
Independent electric motor, pulsator, claw, nozzle and accessories

KAPASİTESİ CAPACITY	2x10 - 12 İnek Sağım 2x10 -1 2 Cow
PULSATÖR PULSATOR	60/40 SütKar Pnömatik 60/40 SütKar Pneumatic
ŞALTER BREAKE	16 A.V. Otomat Topraklı 16 A.V. Otomat Grounded
MOTOR GÜCÜ Monofaze Elektrik Motoru ENGINE POWER Single phase electric	0.75 hp 0.55 kw 1420 dev./dk. 0.75 hp 0.55 kw 1420 dev./min.
POMPA DEBİSİ PUMP FLOW	250 lt/dk. Kuru Kömür Paletli 250 l/min. Dry Coal Crawler





STK-0009

MOBİL TEKLİ KROM GÜĞÜMLÜ SÜT SAĞIM MAKİNASI

MOBILE DOUBLE MILKING SINGLE CHROMIUM CHURN MILK MILKING MACHINE



TEKNİK ÖZELLİKLERİ | TECHNICAL SPECIFICATIONS

Bağımsız elektrik motoru, pulsatör, pençe, memelik ve aksesuarları
Independent electric motor, pulsator, claw, nozzle and accessories

KAPASİTESİ CAPACITY	1x10 - 12 İnek Sağım 1x10 -1 2 Cow
PULSATÖR PULSATOR	60/40 Sütkar Pnömatik 60/40 Sütkar Pneumatic
ŞALTER BREAKE	16 A.V. Otomat Topraklı 16 A.V. Otomat Grounded
MOTOR GÜCÜ Monofaze Elektrik Motoru ENGINE POWER Single phase electric	0.75 hp 0.55 kw 1420 dev./dk. 0.75 hp 0.55 kw 1420 dev./min.
POMPA DEBİSİ PUMP FLOW	250 lt/dk. Kuru Kömür Paletli 250 l/min. Dry Coal Crawler



STK-0010-1

MOBİL ÇİFT SAĞIM BAŞLIKLIL KUYUN SÜT SAĞIM MAKİNASI

MOBILE DOUBLE MILKING SINGLE ALUMINIUM CHURN MILK MILKING MACHINE



TEKNİK ÖZELLİKLERİ | TECHNICAL SPECIFICATIONS

Bağımsız elektrik motoru, pulsatör, pençe, memelik ve aksesuarları
Independent electric motor, pulsator, claw, nozzle and accessories

KAPASİTESİ CAPACITY	2x10 - 12 Küçük Baş Sağım 2x10 -1 2 Sheep Milking
PULSATÖR PULSATOR	50/50 Sütkar Pnömatik 50/50 Sütkar Pneumatic
ŞALTER BREAKE	16 A.V. Otomat Topraklı 16 A.V. Otomat Grounded
MOTOR GÜCÜ Monofaze Elektrik Motoru ENGINE POWER Single phase electric	0.75 hp 0.55 kw 1420 dev./dk. 0.75 hp 0.55 kw 1420 dev./min.
POMPA DEBİSİ PUMP FLOW	250 lt/dk. Kuru Kömür Paletli 250 l/min. Dry Coal Crawler



STK-0010

MOBİL TEKLİ ALÜMİNYUM GÜĞÜMLÜ SÜT SAĞIM MAKİNASI

MOBILE DOUBLE MILKING SINGLE ALUMINIUM CHURN MILK MILKING MACHINE

TEKNİK ÖZELLİKLERİ | TECHNICAL SPECIFICATIONS

Bağımsız elektrik motoru, pulsatör, pençe, memelik ve aksesuarları
Independent electric motor, pulsator, claw, nozzle and accessories

KAPASİTESİ CAPACITY	1x10 - 12 İnek Sağım 1x10 -1 2 Cow
PULSATÖR PULSATOR	60/40 Sütkar Pnömatik 60/40 Sütkar Pneumatic
ŞALTER BREAKE	16 A.V. Otomat Topraklı 16 A.V. Otomat Grounded
MOTOR GÜCÜ Monofaze Elektrik Motoru ENGINE POWER Single phase electric	0.75 hp 0.55 kw 1420 dev./dk. 0.75 hp 0.55 kw 1420 dev./min.
POMPA DEBİSİ PUMP FLOW	250 lt/dk. Kuru Kömür Paletli 250 l/min. Dry Coal Crawler



STK-0010-1-1

MOBİL ÇİFT SAĞIM BAŞLIKLIL ALÜMİNYUM GÜĞÜMLÜ KUYUN SÜT SAĞIM MAKİNASI

MOBILE DOUBLE MILKING CHURN ALUMINIUM MILK SHEEP MILKING MACHINE

TEKNİK ÖZELLİKLERİ | TECHNICAL SPECIFICATIONS

Bağımsız elektrik motoru, pulsatör, pençe, memelik ve aksesuarları
Independent electric motor, pulsator, claw, nozzle and accessories

KAPASİTESİ CAPACITY	2x10 - 12 Küçük Baş Sağım 2x10 -1 2 Sheep Milking
PULSATÖR PULSATOR	50/50 Sütkar Pnömatik 50/50 Sütkar Pneumatic
ŞALTER BREAKE	16 A.V. Otomat Topraklı 16 A.V. Otomat Grounded
MOTOR GÜCÜ Monofaze Elektrik Motoru ENGINE POWER Single phase electric	0.75 hp 0.55 kw 1420 dev./dk. 0.75 hp 0.55 kw 1420 dev./min.
POMPA DEBİSİ PUMP FLOW	250 lt/dk. Kuru Kömür Paletli 250 l/min. Dry Coal Crawler



STK-0010-2 MOBİL 4 SAĞIM BAŞLIKLIL Koyun SÜT SAĞIM MAKİNASI
 MOBILE 4 MILKING CHURN MILK SHEEP MILKING MACHINE

TEKNİK ÖZELLİKLERİ | TECHNICAL SPECIFICATIONS

Bağımsız elektrik motoru, pulsator, pençe, memelik ve aksesuarları
 Independent electric motor, pulsator, claw, nozzle and accessories

KAPASİTESİ CAPACITY	4x10 - 24 Küçük Baş Sağım 4x10 -24 Sheep Milking
PULSATÖR PULSATOR	50/50 SütKar Pnömatik 50/50 SütKar Pneumatic
ŞALTER BREAKE	16 A.V. Otomat Topraklı 16 A.V. Otomat Grounded
MOTOR GÜCÜ Monofaze Elektrik Motoru ENGINE POWER Single phase electric	0.75 hp 0.55 kw 1420 dev./dk. 0.75 hp 0.55 kw 1420 dev./min.
POMPA DEBİSİ PUMP FLOW	250 lt/dk. Kuru Kömür Paletli 250 l/min. Dry Coal Crawler

STK-0010-3-1 MOBİL ÇİFT SAĞIM BAŞLIKLIL ALÜMİNYUM GÜĞÜMLÜ KEÇİ SÜT SAĞIM MAKİNASI
 MOBILE DOUBLE MILKING ALUMINIUM CHURN MILK GOAT MILKING MACHINE

TEKNİK ÖZELLİKLERİ | TECHNICAL SPECIFICATIONS

Bağımsız elektrik motoru, pulsator, pençe, memelik ve aksesuarları
 Independent electric motor, pulsator, claw, nozzle and accessories

KAPASİTESİ CAPACITY	2x10 - 12 Küçük Baş Sağım 2x10 -12 Sheep Milking
PULSATÖR PULSATOR	50/50 SütKar Pnömatik 50/50 SütKar Pneumatic
ŞALTER BREAKE	16 A.V. Otomat Topraklı 16 A.V. Otomat Grounded
MOTOR GÜCÜ Monofaze Elektrik Motoru ENGINE POWER Single phase electric	0.75 hp 0.55 kw 1420 dev./dk. 0.75 hp 0.55 kw 1420 dev./min.
POMPA DEBİSİ PUMP FLOW	250 lt/dk. Kuru Kömür Paletli 250 l/min. Dry Coal Crawler

STK-0010-3 MOBİL ÇİFT SAĞIM BAŞLIKLIL KROM GÜĞÜMLÜ KEÇİ SÜT SAĞIM MAKİNASI
 MOBILE DOUBLE MILKING CHROMIUM CHURN MILK GOAT MILKING MACHINE

TEKNİK ÖZELLİKLERİ | TECHNICAL SPECIFICATIONS

Bağımsız elektrik motoru, pulsator, pençe, memelik ve aksesuarları
 Independent electric motor, pulsator, claw, nozzle and accessories

KAPASİTESİ CAPACITY	2x10 - 12 Küçük Baş Sağım 2x10 -12 Sheep Milking
PULSATÖR PULSATOR	50/50 SütKar Pnömatik 50/50 SütKar Pneumatic
ŞALTER BREAKE	16 A.V. Otomat Topraklı 16 A.V. Otomat Grounded
MOTOR GÜCÜ Monofaze Elektrik Motoru ENGINE POWER Single phase electric	0.75 hp 0.55 kw 1420 dev./dk. 0.75 hp 0.55 kw 1420 dev./min.
POMPA DEBİSİ PUMP FLOW	250 lt/dk. Kuru Kömür Paletli 250 l/min. Dry Coal Crawler

STK-0010-4 MOBİL 4 SAĞIM BAŞLIKLIL KEÇİ SÜT SAĞIM MAKİNASI
 MOBILE 4 MILKING CHURN MILK GOAT MILKING MACHINE

TEKNİK ÖZELLİKLERİ | TECHNICAL SPECIFICATIONS

Bağımsız elektrik motoru, pulsator, pençe, memelik ve aksesuarları
 Independent electric motor, pulsator, claw, nozzle and accessories

KAPASİTESİ CAPACITY	4x10 - 24 Küçük Baş Sağım 4x10 -24 Sheep Milking
PULSATÖR PULSATOR	50/50 SütKar Pnömatik 50/50 SütKar Pneumatic
ŞALTER BREAKE	16 A.V. Otomat Topraklı 16 A.V. Otomat Grounded
MOTOR GÜCÜ Monofaze Elektrik Motoru ENGINE POWER Single phase electric	0.75 hp 0.55 kw 1420 dev./dk. 0.75 hp 0.55 kw 1420 dev./min.
POMPA DEBİSİ PUMP FLOW	250 lt/dk. Kuru Kömür Paletli 250 l/min. Dry Coal Crawler





STK-0010-5

MOBİL ÇİFT SAĞIMLI ÜÇ TEKERLİ SÜT SAĞIM MAKİNESİ
MOBILE DOUBLE MILKING CHURN 3 TIRES MILK MILKING MACHINE



TEKNİK ÖZELLİKLERİ | TECHNICAL SPECIFICATIONS

Bağımsız elektrik motoru, pulsatör, pençe, memelik ve aksesuarları
Independent electric motor, pulsator, claw, nozzle and accessories

KAPASİTESİ CAPACITY	2x10 - 12 İnek Sağım 2x10 -1 2 Cow
PULSATÖR PULSATOR	60/40 Sütkar Pnömatik 60/40 Sütkar Pneumatic
ŞALTER BREAKE	16 A.V. Otomat Topraklı 16 A.V. Otomat Grounded
MOTOR GÜCÜ Monofaze Elektrik Motoru ENGINE POWER Single phase electric	0.75 hp 0.55 kw 1420 dev./dk. 0.75 hp 0.55 kw 1420 dev./min.
POMPA DEBİSİ PUMP FLOW	250 lt/dk. Kuru Kömür Paletli 250 l/min. Dry Coal Crawler



STK-0010-6

MOBİL YARI SABİT SÜT SAĞIM MAKİNASI
MOBILE SEMI FIXED MILKING MACHINE

TEKNİK ÖZELLİKLERİ | TECHNICAL SPECIFICATIONS

Bağımsız elektrik motoru, pulsatör, pençe, memelik ve aksesuarları
Independent electric motor, pulsator, claw, nozzle and accessories

KAPASİTESİ CAPACITY	2x10 - 12 İnek Sağım 2x10 -1 2 Cow
ŞALTER BREAKE	16 A.V. Otomat Topraklı 16 A.V. Otomat Grounded
MOTOR GÜCÜ Monofaze Elektrik Motoru ENGINE POWER Single phase electric	0.75 hp 0.55 kw 1420 dev./dk. 0.75 hp 0.55 kw 1420 dev./min.
POMPA DEBİSİ PUMP FLOW	250 lt/dk. Kuru Kömür Paletli 250 l/min. Dry Coal Crawler



VAKUM MAKİNALARI

VACUUM MACHINE



STK-0063 70'LİK VAKUM MAKİNASI | 70 VACUUM MACHINE

Motor Gücü	0,55 KW	Motor Gücü	0,55 KW
Motor Devri	1400 Dev. / Dak.	Motor Devri	1400 Dev. / Dak.
Motor Emiş Gücü	170 Lt./Dak. 50 kPa	Motor Emiş Gücü	180 Lt./Dak. 50 kPa
Sağım Kapasitesi	0-1 Hayvan	Sağım Kapasitesi	0-1 Hayvan
Motor Özelliği	Kuru tip	Motor Özelliği	Yağlı Tip
Kömür Ölçüleri	4,90 x 43 x 69,80	Fiber Ölçüleri	4,90 x 43 x 69,80

Engine Power	0,55 KW	Engine Power	0,55 KW
Engine Speed	1400 Dev. / Min.	Engine Speed	1400 Dev. / Min.
Engine Suction Power	170 Lt./Min. 50 kPa	Engine Suction Power	180 Lt./Min. 50 kPa
Milking Capacity	0-1 Animal	Milking Capacity	0-1 Animal
Engine Feature	Dry Type	Engine Feature	Oiled Type
Coal Measures	4,90 x 43 x 69,80	Coal Measures	4,90 x 43 x 69,80

STK-0065 450'LİK VAKUM MAKİNASI | 450 VACUUM MACHINE

Motor Gücü	1,5 Kw
Motor Devir	1400 Dev. / Dak.
Çalışma Elektrik Gerilimi	220 & 380 Volt
Emiş Gücü	350 Lt. / Dak 50 kPa
Sağım Kapasitesi	0-4 Hayvan
Motor Özelliği	Yağlı Tip
Fiber Ölçüleri	4,80 x43 x 69,80

Engine Power	1,5 Kw
Engine Speed	1400 Dev. / Min.
Engine Suction Power	220 & 380 Volt
Milking Capacity	350 Lt. / Min. 50 kPa
Engine Feature	0-4 Animal
Engine Suction Power	Oiled Type
Coal measures	4,80 x43 x 69,80

STK-0064 85'LİK VAKUM MAKİNASI | 85 VACUUM MACHINE

Motor Gücü	0,55 KW	Motor Gücü	0,55 KW
Motor Devri	1400 Dev. / Dak.	Motor Devri	1400 Dev. / Dak.
Motor Emiş Gücü	210 Lt./Dak. 50 kPa	Motor Emiş Gücü	220 Lt./Dak. 50 kPa
Sağım Kapasitesi	0-2 Hayvan	Sağım Kapasitesi	0-2 Hayvan
Motor Özelliği	Kuru tip	Motor Özelliği	Yağlı Tip
Çalışma Elektrik Gerilimi	220 Volt	Çalışma Elektrik Gerilimi	220 Volt
Kömür Ölçüleri	4,90 x 41 x 84,80	Fiber Ölçüleri	4,90 x 41 x 84,80

Engine Power	0,55 KW	Engine Power	0,55 KW
Engine Speed	1400 Dev. / Min.	Engine Speed	1400 Dev. / Min.
Engine Suction Power	210 Lt./Min. 50 kPa	Engine Suction Power	220 Lt./Min. 50 kPa
Milking Capacity	0-2 Animal	Milking Capacity	0-2 Animal
Engine Feature	Dry Type	Engine Feature	Oiled Type
Engine Suction Power	220 Volt	Engine Suction Power	220 Volt
Coal Measures	4,90 x 41 x 84,80	Coal Measures	4,90 x 41 x 84,80

STK-0066 1000'LİK VAKUM MAKİNASI | 1000 VACUUM MACHINE

Motor Gücü	2,2 Kw
Motor Devir	1400 Dev. / Dak.
Çalışma Elektrik Gerilimi	220 & 380 Volt
Emiş Gücü	550 Lt. / Dak 50 kPa
Sağım Kapasitesi	0-8 Hayvan
Motor Özelliği	Yağlı Tip
Fiber Ölçüleri	4,80 x43 x 99,80

Engine Power	2,2 Kw
Engine Speed	1400 Dev. / Min.
Engine Suction Power	220 & 380 Volt
Milking Capacity	550 Lt. / Min. 50 kPa
Engine Feature	0-8 Animal
Engine Suction Power	Oiled Type
Coal measures	4,80 x43 x 99,80

STK-0067 1500'LÜK VAKUM MAKİNASI | 1500 VACUUM MACHINE

Motor Gücü	3 Kw
Motor Devir	1400 Dev. / Dak.
Çalışma Elektrik Gerilimi	220 & 380 Volt
Emiş Gücü	850 Lt. / Dak 50 kPa
Sağım Kapasitesi	0-10 Hayvan
Motor Özelliği	Yağlı Tip
Fiber Ölçüleri	4,80 x43 x 149,80

Engine Power	3 Kw
Engine Speed	1400 Dev. / Min.
Engine Suction Power	220 & 380 Volt
Milking Capacity	850 Lt. / Min. 50 kPa
Engine Feature	0-10 Animal
Engine Suction Power	Oiled Type
Coal measures	4,80 x43 x 149,80

STK-0069 2500'LÜK VAKUM MAKİNESİ | 2500 VACUUM MACHINE

Motor Gücü	5 Kw
Motor Devir	1400 Dev. / Dak.
Çalışma Elektrik Gerilimi	380 Volt
Emiş Gücü	1600 Lt. / Dak 50 kPa
Sağım Kapasitesi	1-20 Hayvan
Motor Özelliği	Yağlı Tip
Fiber Ölçüleri	5,90 x85 x 249,80

Engine Power	5 Kw
Engine Speed	1400 Dev. / Min.
Engine Suction Power	380 Volt
Milking Capacity	1600 Lt. / Min. 50 kPa
Engine Feature	0-20 Animal
Engine Suction Power	Oiled Type
Coal measures	5,90 x85 x 249,80

STK-0068 2000'LİK VAKUM MAKİNASI | 2000 VACUUM MACHINE

Motor Gücü	4 Kw
Motor Devir	1400 Dev. / Dak.
Çalışma Elektrik Gerilimi	380 Volt
Emiş Gücü	1250 Lt. / Dak 50 kPa
Sağım Kapasitesi	0-16 Hayvan
Motor Özelliği	Yağlı Tip
Fiber Ölçüleri	4,80 x43 x 199,80

Engine Power	4 Kw
Engine Speed	1400 Dev. / Min.
Engine Suction Power	380 Volt
Milking Capacity	1250 Lt. / Min. 50 kPa
Engine Feature	0-16 Animal
Engine Suction Power	Oiled Type
Coal measures	4,80 x43 x 199,80

STK-0070 2800'LÜK VAKUM MAKİNESİ | 2800 VACUUM MACHINE

Motor Gücü	5 Kw
Motor Devir	1400 Dev. / Dak.
Çalışma Elektrik Gerilimi	380 Volt
Emiş Gücü	2000 Lt. / Dak 50 kPa
Sağım Kapasitesi	1-24 Hayvan
Motor Özelliği	Yağlı Tip
Fiber Ölçüleri	7,90 x 85 x 299,80

Engine Power	5 Kw
Engine Speed	1400 Dev. / Min.
Engine Suction Power	380 Volt
Milking Capacity	2000 Lt. / Min. 50 kPa
Engine Feature	0-24 Animal
Engine Suction Power	Oiled Type
Coal measures	7,90 x85 x 299,80





STK-0321

70'LİK VAKUM POMPASI
70 VACUUM PUMP



STK-0322

85'LİK VAKUM POMPASI
85 VACUUM PUMP



STK-0323

450'LİK VAKUM POMPASI
450 VACUUM PUMP



STK-0324

1000'LİK VAKUM POMPASI
1000 VACUUM PUMP



STK-0325

1500'LÜK VAKUM POMPASI
1500 VACUUM PUMP



STK-0326

2000'LİK VAKUM POMPASI
2000 VACUUM PUMP



STK-0327

2500'LÜK VAKUM POMPASI
2500 VACUUM PUMP



YEDEK PARÇALAR SPARE PARTS



SÜT ÖLÇER VE PEDEMETRE GRUBU | MILK MEASURER AND PEDOMETER GROUP

			
STK-0071 SÜT ÖLÇER ELEKTRONİK ELECTRONIC MILK METER	STK-0071-1 SÜT ÖLÇER GÖVDE MILK METER DRAIN PIPE	STK-0071-2 SÜT ÖLÇER ALT KAPAK DİYAFRAM PEDOMETER	STK-0071-3 SÜT ÖLÇER BOŞALTMA DİYAFRAM KAPAK MILK METER BODY
			
STK-0071-4 SÜT ÖLÇER GÖVDE TAHLYE BORUSU MILK METER UNDER LID	STK-0071-5 SÜT ÖLÇER KAPAK ALT PEDOMETER BELT	STK-0071-6 ELEKTRONİK SÜT ÖLÇER KONTROL PANELİ MILK METER UNDER LID DIAPHRAGM	STK-0071-7 SÜT ÖLÇER ÜST KAPAK ELECTRONIC MILK METER CONTROL BOARD
			
STK-0072 PEDEMETRE PEDOMETER	STK-0073 PEDEMETRE KEMERİ PEDOMETER BELT	STK-0422 MEKANİK SÜT ÖLÇER MECHANIC MILK METER	STK-0432 HAVA KESİCİ AIR STOPPER



SÜT ÖLÇER VE PEDEMETRE GRUBU | MILK MEASURER AND PEDOMETER GROUP

			
STK-0423 OTOMATİK ÇIKARICI AUTOMATIC EXTRACTOR	STK-0433 HAVA KESİCİ GÖVDE AIR STOPPER BODY	STK-00434 HAVA KESİCİ ÜST KAPAK AIR STOPPER UPPER LID	STK-0434-1 HAVA KESİCİ DİYAFRAM ÜST KONTROL KAPAĞI AIR STOPPER DIAPHRAGM UPPER CONTROL LID
			
STK-0436 HAVA KESİCİ DİYAFRAM ORTA BORU AIR STOPPER DIAPHRAGM MIDDLE PIPE	STK-0206 SÜT ÖLÇER ALT-ÜST GÖVDE CONTASI MILK METER UPPER UNDER BODY GASKET	STK-0207 HAVA KESİCİ DİYAFRAM CONTASI AIR STOPPER DIAPHRAGM GASKET	STK-0208 SÜT ÖLÇER MEKANİK HAREKET BORU CONTASI MECHANIC MILK METER ACTION PIPE GASKET





SÜT LASTİĞİ VE HORTUM GRUBU | MILK TIRES AND HOSE GROUP



SÜT LASTİĞİ VE HORTUM GRUBU | MILK TIRES AND HOSE GROUP





SÜT LASTİĞİ VE HORTUM GRUBU | MILK TIRES AND HOSE GROUP

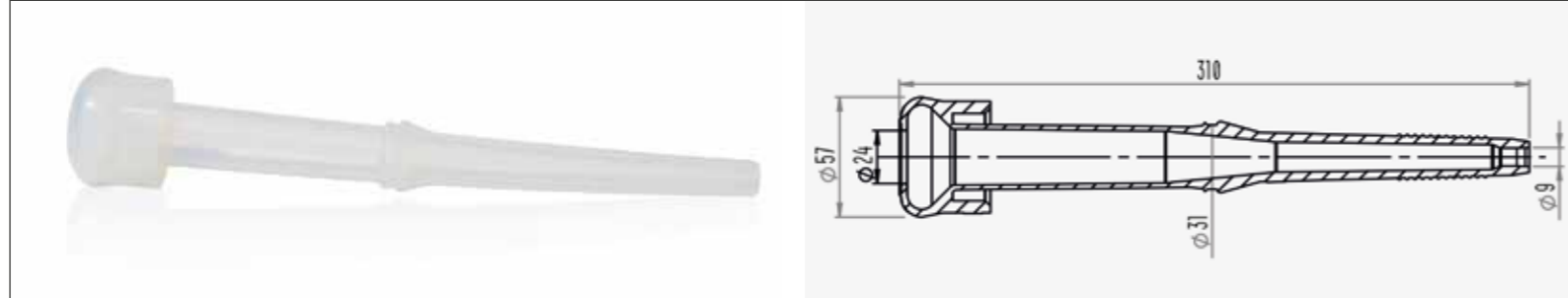

STK-0111

UZUN SÜT LASTİĞİ SİLİKON | LONG MILK TIRE SILICON

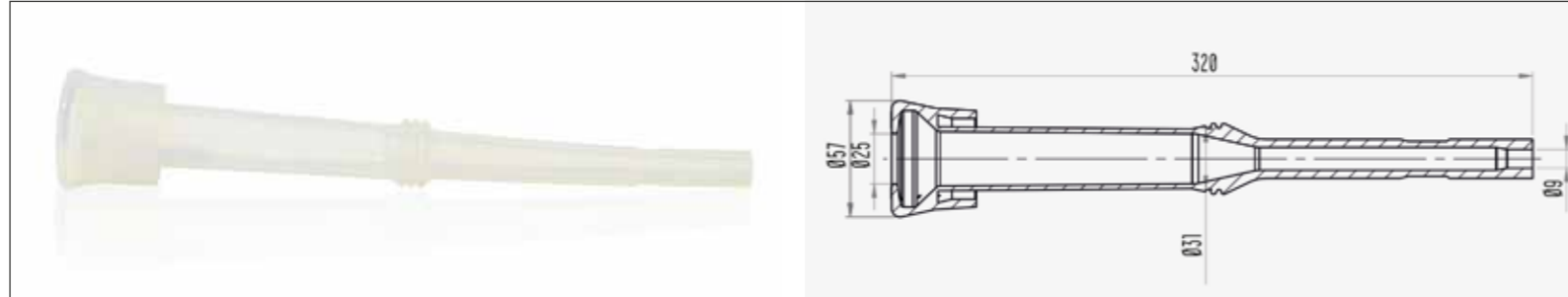

STK-0112

UZUN SÜT LASTİĞİ SİLİKON | LONG MILK TIRE SILICON



STK-0120

HAVA HORTUMU | AIR PIPE



STK-0121

KISA SÜT HORTUMU | SHORT MILK PIPE



SÜT LASTİĞİ VE HORTUM GRUBU | MILK TIRES AND HOSE GROUP

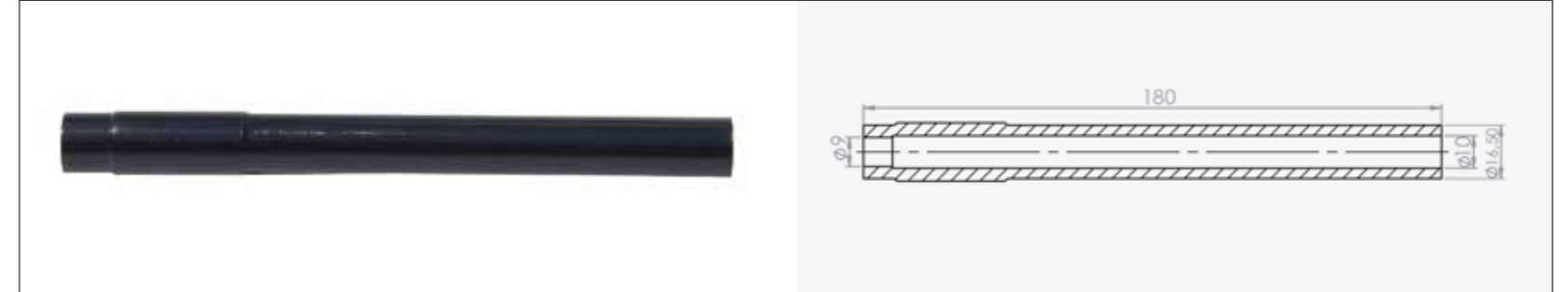

STK-0122

UZUN SÜT HORTUMU | LONG MILK PIPE

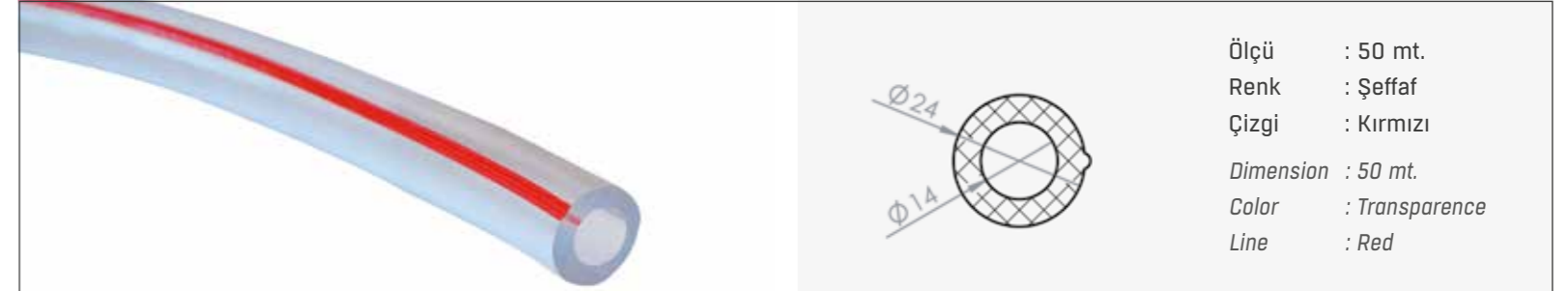

STK-0123

TEKLİ SÜT HORTUMU | SINGLE MILK PIPE

Ölçü : 50 mt.
Renk : Şeffaf
Çizgi : Kırmızı
Dimension : 50 mt.
Color : Transparence
Line : Red

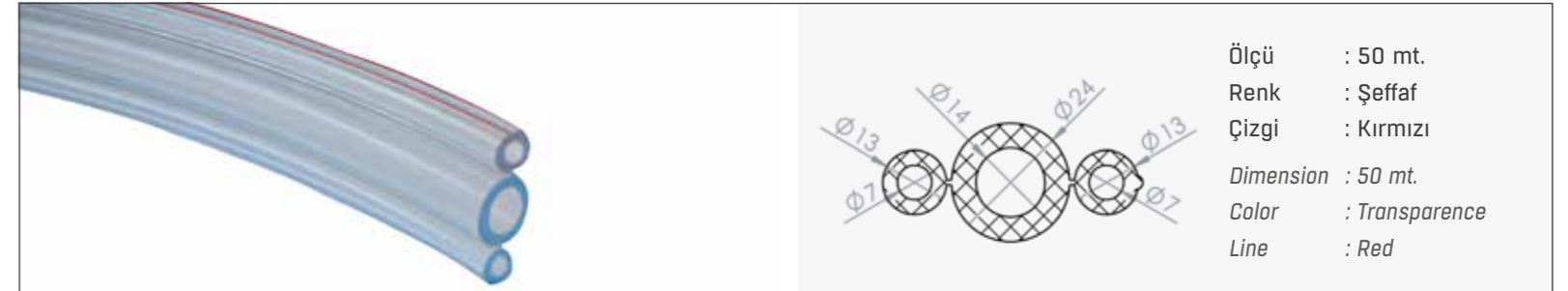

STK-0124

ÜÇLÜ SÜT HORTUMU | TRIPLE MILK PIPE

Ölçü : 50 mt.
Renk : Şeffaf
Çizgi : Kırmızı
Dimension : 50 mt.
Color : Transparence
Line : Red

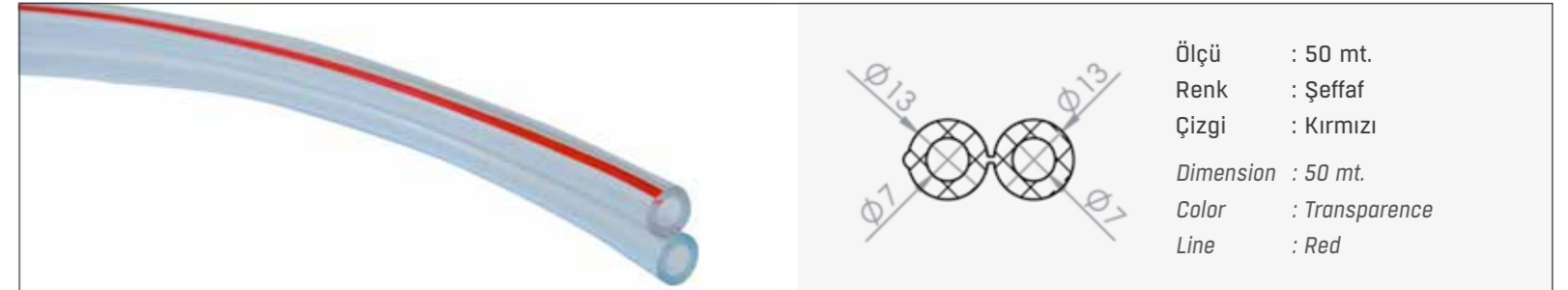

STK-0125

ÇİFTLİ NABİZ HORTUMU | DOUBLE PULSE PIPE

Ölçü : 50 mt.
Renk : Şeffaf
Çizgi : Kırmızı
Dimension : 50 mt.
Color : Transparence
Line : Red















PENÇE GRUBU | CLAW GROUP

			
STK-0131	STK-0132	STK-0133	STK-0134-1
150 CC PENÇE 150 CC CLAW	150 CC PENÇE KAPAK TAKIM 150 CC CLAW LID GROUP	150 CC PENÇE GÖVDE 150 CC CLAW BODY	150 -160 CC PENÇE HAVA DAĞITICI 150-160 CC CLAW AIR DISTRIBUTOR
			
STK-0135	STK-0136	STK-0137	STK-0138
150 -160 CC PENÇE CONTASI 150-160 CLAW GASKET	150 CC PENÇE SAĞIM DEMETİ 150 MILKING BUNCH	150 CC PENÇE KÜRE KELEBEK TAKIM 150 CC CLAW SPHERE BUTTERFLY GORUP	150 CC PENÇE ÜST CAMI 150 CC CLAW UPPER GLASS
			
STK-0139	STK-0140	STK-0141	STK-0144
PENÇE KELEBEK CLAW BUTTERFLY	160 CC PENÇE 160 CC CLAW	160 CC PENÇE KAPAK TAKIM 160 CC CLAW LID GORUP	160 CC PENÇE KÜRE KELEBEK TAKIM 160 CC CLAW SPHERE BUTTERFLY GORUP



PENÇE GRUBU | CLAW GROUP

			
STK-0144-1	STK-0145	STK-0146	STK-0147
160 CC PENÇE KÜRE KELEBEK VIDALI 160 CC CLAW SPHERE BUTTERFLY CREW	160 CC PENÇE ALTI 160 CC UNDER CLAW	160 CC PENÇE SAĞIM DEMETİ 160 CC CLAW MILKING BUNCH	160 CC PENÇE ÜST CAMI 160 CC CLAW UPPER GLASS
			
STK-0150	STK-0151	STK-0152	STK-0153
200 CC PENÇE 200 CC CLAW	200 CC PENÇE KAPAK TAKIM 200 CC CLAW LID GORUP	200 CC PENÇE ALTI 200 CC UPPER CLAW	200 CC PENÇE HAVA DAĞITICI 200 CC CLAW AIR DISTRIBUTOR
			
STK-0154	STK-0155	STK-0156	STK-0158
200 CC PENÇE CONTASI 200 CC CLAW GASKET	200 CC PENÇE KÜRE KELEBEK TAKIM 200 CC CLAW SPHERE BUTTERFLY GORUP	200 CC PENÇE ÜST CAMI 200 CC CLAW UPPER GLASS	200 CC PENÇE SAĞIM DEMETİ 200 CC CLAW MILKING BUNCH



PENÇE GRUBU | CLAW GROUP



STK-0159

240 CC PENÇE
240 CC CLAW

STK-0160

240 CC PENÇE KAPAK TAKIM
240 CC CLAW LID GROUP

STK-0162

240-340 CC PENÇE ALTI
240-340 CC UNDER CLAW

STK-0163

240-340 CC PENÇE HAVA DAĞITICI
240-340 CC CLAW AIR DISTRIBUTOR

STK-0164

240 -340 CC PENÇE CONTASI
240 -340 CC CLAW GASKET

STK-0165

240-340 CC PENÇE ORTA MİL ORİNGİ
240-340 CC CLAW MIDDLE MIL ORINGI

STK-0166

240 CC PENÇE ASKISI
240 CC CLAW HANGER

STK-0168

240 -340 CC PENÇE KÜRE KELEBEK
TAKIM
240 -340 CC CLAW SPHERE BUTTERFLY
GORUP

STK-0170

240 CC PENÇE ÜST CAMI
240 CC UPPER GLASS

STK-0171

240 CC PENÇE SAĞIM DEMETİ
240 CC CLAW MILKING BUNCH

STK-0172

340 CC PENÇE
340 CC CLAW

STK-0173

340 CC PENÇE KAPAK TAKIM
340 CC CLAW LID GROUP

PENÇE GRUBU | CLAW GROUP



STK-0179

340 CC PENÇE ASKISI
340 CC CLAW HANGER

STK-0183

340 CC PENÇE ÜST CAMI
340 CC CLAW UPPER GLASS

STK-0184

340 CC PENÇE SAĞIM DEMETİ
340 CC CLAW MILKING BUNCH

VAKUM TANKI GRUBU | VACUUM TANK GROUP



STK-0230

SÜTKAR VAKUM TANKI
SÜTKAR VACUUM TANK

STK-0231

VAKUM TANK-1
VACUUM TANK 1

STK-0232

VAKUM TANK-2
VACUUM TANK 2

STK-0233

VAKUM TANK-3
VACUUM TANK 3



REZERVE VE FANUS GRUBU | RESERVE AND FAUNUS GROUP

			
STK-0317	STK-0318	STK-0319	STK-0320
REZERVE TANKI 50 LT REZERVE TANK 50 LT	REZERVE TANKI 60 LT REZERVE TANK 60 LT	REZERVE TANKI 100 LT REZERVE TANK 100 LT	CAM FANUS BELL GLASS
			
STK-0412	STK-0413	STK-0455	
KROM SIVI SEVİYE ÇUBUĞU CHROMIUM LIQUID LEVEL STICK	SIVI SEVİYE TOPU KROM CHROMIUM LIQUID LEVEL BALL	AKTARMA POMPASI TRANSFER PUMP	



GÜĞÜM GRUBU | CHURN GROUP

			
STK-0251	STK-0252	STK-0253	STK-0254
30'LUK ALÜMİNYUM GÜĞÜM 30 ALUMINIUM CHURN	30'LUK KROM GÜĞÜM 30 CHROMIUM CHURN	40'LİK ALÜMİNYUM GÜĞÜM 40 ALUMINIUM CHURN	40'LİK KROM GÜĞÜM 40 CHROMIUM CHURN

KAPAK GRUBU | COVER GROUP

	
STK-0185	STK-0186
30'LUK GÜĞÜM KAPAK 2 DELİKLİ 30 CHURN LID 2 HOLE	30'LUK GÜĞÜM KAPAK 3 DELİKLİ 30 CHURN LID 3 HOLE
	
STK-0187	STK-0188
30'LUK PASLANMAZ GÜĞÜM KAPAK 30 CHURN STAINLESS LID	30'LUK KAUCUK TAŞIMA KAPAK 30 RUBBER LID

Malzeme : Inox
Ağız Çapı : Ø 185
Giriş Çapı : Ø 42 x Ø 42
Ağırlık : 995 gr.
Conta Dahildir.

Material : Inox
Opening Diameter : Ø 185
Nipple Diameter : Ø 42 x Ø 42
Weight : 995 gr.
The Gasket is Included.



KAPAK GRUBU | COVER GROUP



Malzeme : Inox
Ağız Çapı : Ø 191
Giriş Çapı : Ø 42 x Ø 42
Ağırlık : 895 gr.
Conta Dahildir.
Material : Inox
Opening Diameter : Ø 191
Nipple Diameter : Ø 42 x Ø 42
Weight : 895 gr.
The Gasket is Included.

STK-0189
40'LIK TRANSFER GÜĞÜM KAPAK | 40 TRANSFER CHURN LID



STK-0190
40'LIK GÜĞÜM KAPAK | 40 CHURN LID



STK-0191
40'LIK GÜĞÜM DÜZ KAPAK 1 | 40 CHURN FLAT LID 1



STK-0192
40'LIK DÜZ GÜĞÜM KAPAK 2 | 40 CHURN FLAT LID 2



STK-0193
50 LT TAŞIMA GÜĞÜM KAPAK | 50 LT TRANSPORT CHURN LID



STK-0194
VAKUM TANK KAPAK | VACUUM TANK LID



STK-0195
VAKUM TANK KAPAĞI-1 | VACUUM TANK LID 1



STK-0426
GÜĞÜM KAPAK DELİK TAPASI | CHURN LID HOLE STOPPER



PULSATÖR GRUBU | PULSATOR GROUP



STK-0220
2 TELLİ ELEKTRONİK PULSATÖR
2 WIRES ELECTRONIC PULSATOR



STK-0221
3 TELLİ ELEKTRONİK PULSATÖR
3 WIRES ELECTRONIC PULSATOR



STK-0222
MEKANİK PULSATÖR
MECHANIC PULSATOR



STK-0224
MEKANİK PULSATÖR KIZAK TAKIMI
MECHANIC PULSATOR SLIDE GROUP



STK-0225
PULSATÖR DİYAFRAM KÜÇÜK
PULSATOR DIAPHRAGM SMALL



STK-0226
PULSATÖR DİYAFRAM BÜYÜK
PULSATOR DIAPHRAGM LARGE



STK-0227
PULSATÖR DİYAFRAM TAKIMI
PULSATOR DIAPHRAGM GROUP



STK-0407
MEKANİK PULSATÖR GİRİŞİ
MECHANIC PULSATOR INPUT



KAUÇUK GRUBU | RUBBER GROUP

			
STK-0311-1	STK-0314	STK-0315	STK-0316
63'LÜK KAUÇUK BORU KÖR TAPASI 63 RUBBER PIPE BLIND STOPPER	HAVA TANKI TAHLİYE KÖR TAPA AIR TANK DISCHARGE BLIND STOPPER	REZERVE KAUÇUK KÖR TAPA RESERVE RUBBER BLIND STOPPER	MEMELİK KÖR TAPA BLIND STOPPER FOR BREAST

	STK-0276 Ø 40 KAUÇUK MANŞON Ø 40 RUBBER MUFF
	STK-0277 Ø 50 KAUÇUK MANŞON Ø 50 RUBBER MUFF
	STK-0278 Ø 63 KAUÇUK MANŞON Ø 63 RUBBER MUFF
	STK-0279 Ø 75 KAUÇUK MANŞON Ø 75 RUBBER MUFF

	STK-0287 Ø 40 KAUÇUK DİRSEK Ø 40 RUBBER BRACKET
	STK-0288 Ø 50 KAUÇUK DİRSEK Ø 50 RUBBER BRACKET
	STK-0289 Ø 63 KAUÇUK DİRSEK Ø 63 RUBBER BRACKET
	STK-0290 Ø 75 KAUÇUK DİRSEK Ø 75 RUBBER BRACKET
	STK-0291 Ø 90 KAUÇUK DİRSEK Ø 90 RUBBER BRACKET

	STK-0309 Ø 40 KAUÇUK KÖR TAPA Ø 40 RUBBER BLIND STOPPER
	STK-0310 Ø 50 KAUÇUK KÖR TAPA Ø 50 RUBBER BLIND STOPPER



CONTA GRUBU | GASKET GROUP

			
STK-0196		STK-0198	
30'LÜK GÜĞÜM KAPAK CONTASI 30 CHURN LID GASKET		40'LÜK GÜĞÜM KAPAK CONTASI 40 CHURN LID GASKET	
			
STK-0199		STK-0201	
40'LÜK DÜZ KAPAK CONTASI 40 FLAT LID GASKET		REZERVE KAPAK CONTASI RESERVE LID GASKET	
			
STK-0202		STK-0203	STK-0204
DIŞ KAPAK CONTASI EXTERNAL LID GASKET		İÇ KAPAK CONTASI INTERNAL LID GASKET	SIVI SEVİYE REZERVE GİRİŞ CONTASI LIQUID LEVEL RESERVE INPUT GASKET
			
STK-0205			
SÜT GİRİŞ CONTASI MILK INPUT GASKET			



PVC GRUBU | PVC GROUP



STK-0292 Ø 40 PVC DİRSEK | Ø 40 PVC BRACKET

STK-0293 Ø 50 PVC DİRSEK | Ø 50 PVC BRACKET

STK-0294 Ø 63 PVC DİRSEK | Ø 63 PVC BRACKET

STK-0295 Ø 75 PVC DİRSEK | Ø 75 PVC BRACKET

STK-0296 Ø 90 PVC DİRSEK | Ø 90 PVC BRACKET



STK-0281 Ø 40 PVC MANŞON | Ø 40 PVC MUFF

STK-0282 Ø 50 PVC MANŞON | Ø 50 PVC MUFF

STK-0283 Ø 63 PVC MANŞON | Ø 63 PVC MUFF

STK-0284 Ø 75 PVC MANŞON | Ø 75 PVC MUFF

STK-0285 Ø 90 PVC MANŞON | Ø 90 PVC MUFF



STK-0304 Ø 40 PVC KÖR TAPA | Ø 40 PVC BLIND STOPPER

STK-0305 Ø 50 PVC KÖR TAPA | Ø 50 PVC BLIND STOPPER

STK-0307 Ø 75 PVC KÖR TAPA | Ø 75 PVC BLIND STOPPER

STK-0308 Ø 90 PVC KÖR TAPA | Ø 90 PVC BLIND STOPPER



PVC GRUBU | PVC GROUP



STK-0277-2

50'LİK PVC BORU
50 PVC PIPE



STK-0277-3

50'LİK PVC TE
50 PVC T



STK-0277-7

63'LÜK PVC TE
63 PVC T



STK-0386

KÜRESEL VANA
GLOBAL VALVE



STK-0306

63'LÜK PVC KÖR TAPA
PVC BLIND STOPPER



STK-0311-3

63'LÜK PVC BORU
63 PVC PIPE



STK-0384

1/2 YİVSİZ ÇİFT YÖNLÜ VANA
1/2 DOUBLE WAY VALVE



STK-0385

1/2-16 PVC VANA
1/2-16 PVC VALVE



STK-0364

PVC YIKAMA HORTUM GİRİŞİ
PVC WASHING PIPE INPUT



BAŞLIK GRUBU | HEADER GROUP



STK-0370

KOYUN BAŞLIĞI MANUEL KAUCUK
SHEEP HEADER MANUEL RUBBER

STK-0371

KOYUN BAŞLIĞI SİLİKON YARI
OTOMATİK
SHEEP HEADER SILICON SEMI AUTO

STK-0372

KOYUN BAŞLIĞI OTOMATİK
SHEEP HEADER AUTOMATIC

STK-0373

KEÇİ SAĞIM BAŞLIĞI SİLİKON
GOAT HEADER SILICON

STK-0362

YIKAMA BAŞLIK KELEPÇESİ TAKIM
WASHING HEADER LOCKER GROUP

TEKER GRUBU | TIRE GROUP



STK-0277-1

50'LİK PRİZ KOLYE
50 SOCKET NECKLACE

STK-0311-2

63'LÜK PRİZ KOLYE
63 SOCKET NECKLACE

STK-0298

63'LÜK KATRIJ DİRSEK
63 KATRIJ BRACKET

STK-0340

25'LİK TEKER
25 TIRE

STK-0341

30'LÜK TEKER
30 TIRE

STK-0342

FRENLİ SARHOŞ TEKER
DRUNK TIRE WITH BRAKE

STK-0379

27'LİK AYAK TAKOZU
27 FOOT WEDGE

STK-0380

32'LİK AYAK TAKOZU
32 FOOT WEDGE

STK-0381

70'LİK ÇEKVALF
70 CHECK VALVE

STK-0382

85'LİK ÇEKVALF
85 CHECK VALVE

STK-0383

27'LİK ELCEK



FİBER VE GRAFİT PALET GRUBU | FIBER AND GRAPHITE PALLET



STK-0255	FİBER 650 4,90X40X65,5 FIBER 650 4,90X40X65,5
STK-0256	FİBER 700 4,90X41X70 FIBER 700 4,90X41X70
STK-0257	FİBER 700 4,90X43X70 FIBER 700 4,90X43X70
STK-0258	FİBER 700/46 70X46X6 FIBER 700/46 70X46X6
STK-0259	FİBER 800 4,90X43X80 FIBER 800 4,90X43X80
STK-0260	FİBER 850 4,90X41X85 FIBER 850 4,90X41X85
STK-0261	FİBER 850155 5,90X55X85 FIBER 850155 5,90X55X85
STK-0262	FİBER 1000 4,90X41,5X100 FIBER 1000 4,90X41,5X100
STK-0263	FİBER 1500 4,90X41,5X150 FIBER 1500 4,90X41,5X150
STK-0264	FİBER 2000 4,90X41,5X200 FIBER 2000 4,90X41,5X200
STK-0265	FİBER 2500 4,90X41,5X200 FIBER 2500 4,90X41,5X200



STK-0266	GRAFİT PALET 65X40 GRAPHITE PALLET 65X40
STK-0267	GRAFİT PALET 65,5X40X4,90 GRAPHITE PALLET 65,5X40X4,90
STK-0268	GRAFİT PALET 4,90X41,70 GRAPHITE PALLET 4,90X41,70
STK-0269	GRAFİT PALET 70X43X4,90 GRAPHITE PALLET 70X43X4,90
STK-0270	GRAFİT PALET 6X46X70 GRAPHITE PALLET 6X46X70
STK-0271	GRAFİT PALET 75X41X4,90 GRAPHITE PALLET 75X41X4,90
STK-0272	GRAFİT PALET 75X43X4,90 GRAPHITE PALLET 75X43X4,90
STK-0273	GRAFİT PALET 4,90X43X80 GRAPHITE PALLET 4,90X43X80
STK-0274	GRAFİT PALET 4,90X41X85 GRAPHITE PALLET 4,90X41X85
STK-0275	GRAFİT PALET 4,90X40X86 GRAPHITE PALLET 4,90X40X86



ANKASTRE GRUBU | FLUSH GROUP



STK-0277-5

50'LİK U BOLT
50 U BOLT

STK-0311-4

63'LÜK U BOLT
63 U BOLT

STK-0277-6

50'LİK KROM BORU KELEPÇESİ
50 CHROMIUM PIPE CLAMP

STK-0350

15 CM LAMA ANKASTRE
15 CM LAMA FLUSH

STK-0351

20 CM LAMA ANKASTRE
20 CM LAMA FLUSH

STK-0352

25 CM LAMA ANKASTRE
25 CM LAMA FLUSH

STK-0353

35 CM LAMA ANKASTRE
35 CM LAMA FLUSH

STK-0360

YIKAMA BAŞLIK KROM ANKASTRE
WASHING HEADER CHROMIUM FLUSH

STK-0376

70'LİK EGSOZ
70 EXHAUST

STK-0377

85'LİK EGSOZ
85 EXHAUST

STK-0378

MOBİL YAĞLI MAKİNE EGSOZ
MOBILE OILED MACHINE EXHAUST

STK-0406

KROM EĞRİ BOYUN SÜT GİRİŞİ
CHROMIUM CURVE NECK MILK INPUT



ANKASTRE GRUBU | FLUSH GROUP



STK-0400

KROM PENÇE ASKISI
CHROMIUM CLAW HANGER

STK-0405

KROM DÜZ SÜT GİRİŞİ
CHROMIUM FLAT MILK INPUT

KARMA GRUP | MIXED GROUP



STK-0217

MOTOR MİL MUHAFAZASI
ENGINE MILE PRESERVATION

STK-0311-5

63-50 REDÜKSİYON DÜŞÜRÜCÜ
63-50 REDUCTION REDUCER

STK-0363

YIKAMA SU DAĞITICI
WASHING WATER SEPERATOR

STK-0365

KROM YIKAMA KÜVETİ 100 LT
CHROMIUM WASHING TUB 100 LT

KARMA GRUP | MIXED GROUP



STK-0387

MOBİL MAKİNA VAKUM SAATİ KÜÇÜK
MOBILE MACHINE VACUUM CLOCK SMALL

STK-0388

SAĞIM SİSTEMİ VAKUM SAATİ BÜYÜK
MILKING SYSTEM VACUUM CLOCK BIG

STK-0389

MOBİL MAKİNA REGÜLATÖR
MOBILE MACHINE REGULATOR

STK-0390

SAĞIM SİSTEMİ REGÜLATÖR
MILKING MACHINE REGULATOR

STK-0392

SÜTKAR SÜT GÖZLEM CAMI
SÜTKAR MILK OBSERVATION GLASS

STK-0393

SÜT AKIŞ GÖSTERGE CAMI
SÜTKAR MILK FLOW GLASS

STK-0394

KROM KILIF
CHROMIUM CASE

STK-0395

KILIF TAKIMI
CASE GROUP

STK-0397

KADEH | GLASS















STK-0398

KADEH 1 | GLASS 1





KARMA GRUP | MIXED GROUP

			
STK-0396	STK-0399	STK-0414	STK-0415
PLASTİK KILIF PLASTIC CASE	MOBİL YAĞDANLIK MOBILE OILER	KISA FIRÇA SHORT BRUSH	UZUN FIRÇA LONG BRUSH
			
STK-0418	STK-0419	STK-0420	STK-0425
BİBERON EMZİŐİ BOTTLE NIPPLE	DALDIRMA KABI DIPPING POT	KABLO SARMA APARATI PIPE WRAPPING TOOL	AKTARMA POMPASI TAHLİYE KLEPESİ TRANSPORT PUMP DISCHARGE KLEPE
			
STK-0421	STK-0431	STK-0429	STK-0424
KOVA EMZİŐİ BUCKET NIPPLE	TEKMELİK KICKING	SIYIRICI PANOSU STRIPPER BOARD	SIYIRICI REDÜKTÖR STRIPPER REDUCTOR



TEMİZLİK GRUBU | CLEANING GROUP

	STK-0366 ALKALİ 20 LİTRE ALKALI 20 LİTER
	STK-0368 ALKALİ 5 LİTRE ALKALI 5 LİTER
	STK-0367 ASİT 20 LİTRE ASIT 20 LİTER
	STK-0369 ASİT 5 LİTRE ASIT 5 LİTER
	STK-0369-1 SAĞIM SONRASI HİJYEN JEL 20 LİTRE AFTER MILKING JEL 20 LİTER
	STK-0369-2 SAĞIM SONRASI HİJYEN JEL 5 LİTRE AFTER MILKING JEL 5 LİTER





Büsan Özel Organize Sanayi Bölgesi Fevzi Çakmak Mh.
Aslım Caddesi No:53/E Karatay / Konya

T: 0332 503 07 79 | M: 0532 483 58 95
sutkar@sutkar.com.tr | www.sutkar.com.tr